

AS320 Series Elevator Inverter

Publication Status: Standard

Product edition: V2.10

All Copyright© reserved by Shanghai STEP Electric Corporation

All rights reserved

The information in this document is subject to change without prior notice. No part of this document may in any form or by any means (electronic, mechanical, micro-coping, photocopying, recording or otherwise) be reproduced, stored in a retrieval system or transmitted without prior written permission from Shanghai STEP Electric Corporation.

Forward

AS320 Series Elevator Inverter is a new product developed based on characteristics of elevator transport. It uses specific 32-bit microprocessor for motor, CPLD (Complex Programmable Logic Device) and the most advanced power module. A leading technology of closed loop VC (Vector Control) is also adopted. It supports V/F (voltage vector), SVC (Sensor-less Vector Control) and torque control mode as well, combining with the characteristic of potential energy load, it operates elevator reliably, comfortably and efficiently.

Abstract

This is a comprehensive manual for AS320 Series elevator inverter in installation, operation, functions and parameters setting, maintenance and failure processing. This manual can be referred as reference document by elevator control design which uses AS320 Series Elevator Inverter. It can also be used in installation, adjustment and maintenance.

To ensure correct installation and operation, please read this manual carefully before use of this product.

Readers

User
Elevator control design engineer
Maintenance staffs
Customer technical support staffs

Innovative Characteristics

- a) With the new innovative technology of no-load sensor compensation starting, elevator obtains excellent comfort at starting without weight device;
- b) Synchronous motor can be controlled by using incremental ABZ encoder, no-load sensor compensation starting technology provides smooth starting;
- c) New PWM dead time compensation can effectively reduce motor noise, wear and tear;
- d) Dynamic PWM carrier technology can reduce motor noise effectively;
- e) Sync motor self-adjusts phase angle without encoder;
- f) Asynchronous motor can adjust itself without encoder as well, as long as the

motor parameters are set accurately. If motor parameters can't be obtained on-site, the inverter can get motor accurate parameters automatically by simply using the static motor self-learning method without such complex work like lifting the car cab;

g) New sixth generation module of hardware with low θ_{j} is used, whose junction temperature resistance up to 175°C, and lower loss for switch and connection.

Simple & Fast Commissioning Method To The Elevator

It is crucial whether the elevator debugging method convenient or not, after the inverter wired. It's costs a lot of time and efforts to set lots of parameters and to complete complex operating procedures. As this inverter is specifically designed for elevator, the elevator commissioning is extremely simple and fast, only requiring 3 steps which shown as follows:

(1) Parameter setting

- a) Re-set all parameters to default factory set values by operator;
- b) Then set parameters of motor and encoder according their name plate.

(2) Run direction setting

The correctness of motor running direction and encoder connection can easily be judged by the operator. A mistake can be simply adjusted by changing parameters.

(3) Adjust comfort

- a) A factory set value provides a considerable comfort even without any parameter modification;
- b) A further minor PID adjustment will achieve a prefect comfort.

Content Statement

The manual may be update and supplied; please visit our company website for the update regularly.

Our company website: www.stepelectric.com.

Safety-related Signs

All safety related contents in this manual are marked following labels. All contents attached with these safety signs are important and must be followed strictly.



Danger

Indicates a hazardous situation, if a mistake operation could result in death or serious injury.



Caution

Indicates a hazardous situation, if a mistake operation could result in minor or severe injury and equipment trouble.



Important

Need to be followed and pay grater attention.

Chapter 1 The Using Notes Of Inverter**Chapter 2 Model And Specification****Chapter 3 Mechanical Installation Of The Inverter****Chapter 4 The Wiring Of The Inverter****Chapter 5 Operator****Chapter 6 Functional Parameters****Chapter 7 Elevator Operation Guide****Chapter 8 Fault Check****Chapter 9 Service And Maintenance****Appendix A Inverter EMC Installation Guide****Appendix B Full List Of Function Parametrs, Fault Sheets****Appendix C Standard Compatibility**

Menu

CHAPTER 1	THE USING NOTES OF INVERTER	1
1.1	VOLTAGE LEVEL AND ADAPTABLE MOTOR CAPACITY	1
1.2	OUT OF BOX AUDIT (OOBA).....	1
1.3	DESCRIPTION OF INVERTER MODEL	1
1.4	DESCRIPTION OF INVERTER NAMEPLATE	2
1.5	SAFETY PRECAUTIONS	3
1.6	OPERATING NOTICE	5
1.6.1	Select braking resistor	5
1.6.2	No absorber at output.....	6
1.6.3	Operating voltage.....	6
1.6.4	Avoid 2-phases input.....	6
1.6.5	The user application control to output contactor.....	6
1.6.6	Altitude vs. descendent rated current	6
1.6.7	Ambient temperature vs. descendent rating power.....	7
1.6.8	Synchronous sealing star delay	7
1.6.9	Accord with low voltage directive	7
1.7	DISCARD AS USELESS NOTICE	8
1.7.1	Capacitor handling	8
1.7.2	Plastic piece handling.....	8
CHAPTER 2	MODEL AND SPECIFICATION	9
2.1	MODEL.....	9
2.2	TECHNICAL INDEXES AND SPECIFICATIONS OF THE INVERTER	10
2.2.1	200V Level Inverter Specifications.....	10
2.2.2	400V Level Inverter Specifications.....	11
2.2.3	General indexes and specifications	11
2.3	MOUNTING DIMENSION AND WEIGHT OF THE INVERTER	14
2.4	OPERATOR DIMENSION	16
CHAPTER 3	MECHANICAL INSTALLATION OF THE INVERTER.....	17
3.1	INSTALLED LOCATION.....	17
3.2	THE INSTALLATION DIRECTION AND SPACE REQUIREMENTS OF THE INVERTER.....	18
3.3	INVERTER INSTALLATION.....	19
3.4	DISASSEMBLY/ASSEMBLY INVERTER SHELL	19
3.4.1	Overall shape, and the names of its parts	19
3.4.2	Connect/disconnect the operator	20
3.4.3	Open/close wiring cap.....	21
3.4.4	Mount/dismount front panel.....	21
CHAPTER 4	THE WIRING OF THE INVERTER	23
4.1	CONNECT INVERTER TO PERIPHERALS	24
4.1.1	Connection diagram between inverter and peripherals	24

4.1.2 Connect inverter to peripherals	25
CHAPTER 5 OPERATOR	33
5.1 FUNCTION FOR INDIVIDUAL PARTS.....	33
5.1.1 LED indicator.....	33
5.1.2 LED Digital tube.....	34
5.1.3 LCD display.....	34
5.1.4 Keyboard.....	34
5.2 OPERATION.....	35
5.2.1 Display after power on.....	35
5.2.2 “Monitor State” in detail.....	35
5.2.3 “Control Panel”.....	36
5.2.4 Operation mode.....	36
5.3 FAULT INDICATION.....	38
CHAPTER 6 FUNCTIONAL PARAMETERS.....	41
6.1 FUNCTIONAL CLASSIFICATION	41
6.2 LIST OF DETAILS OF FUNCTIONS AND THEIR DESCRIPTIONS.....	41
6.2.1 Password and basic control mode	41
6.2.2 Motor and encoder parameters, self learning commands.....	43
6.2.3 PID regulator and start/brake adjusting parameters	47
6.2.4 Speed reference parameters.....	52
6.2.5 Torque reference, torque compensation parameters.....	57
6.2.6 Binary input parameters.....	60
6.2.7 Binary output parameters.....	63
6.2.8 Analog input function parameters	69
6.2.9 Analog output function, LCD and LED content display parameters.....	70
6.2.10 Other information.....	73
CHAPTER 7 ELEVATOR OPERATION GUIDE	79
7.1 INTRODUCTION.....	79
7.2 DESCRIPTION OF SPEED REFERENCE MODE	82
7.3 DESCRIPTION OF CONNECTION BETWEEN ELEVATOR CONTROL AND INVERTER	83
7.3.1 Reference diagram for wiring in analog speed mode.....	83
7.3.2 Reference wiring diagram for wiring in multi-speed mode	85
7.4 BASIC PARAMETER SETTING	87
7.4.1 Speed reference mode setting.....	87
7.4.2 Traction motor setting	87
7.5 MOTOR PARAMETERS SELF-LEARNING GUIDE.....	89
7.6 ADJUST ELEVATOR MOVING DIRECTION	90
7.7 ADJUST SPEED CURVE.....	92
7.7.1 Adjustment in analog speed reference mode.....	93
7.7.2 Adjustment in multi-speed reference mode.....	93
7.8 COMFORTABILITY TUNING.....	97
7.8.1 Comfort tuning at start	98

7.8.2 Comfort tuning during moving	100
7.8.3 Comfort tuning at stop	103
7.9 ADDITIONAL FUNCTION DESCRIPTION.....	103
7.9.1 Introduction – preload weighing compensation method through analog input	103
7.9.2 Starting compensation method by using light/heavy duty switch	106
7.9.3 Bus low voltage operation mode for emergent leveling.....	108
7.9.4 Wiring and parameter setting method for a single contactor in main circuit.....	110
CHAPTER 8 FAULT CHECK	113
8.1 THE FUNCTION OF PROTECTION AND CHECK	113
8.2 FAULT DIAGNOSIS PROCEDURE	121
CHAPTER 9 SERVICE AND MAINTENANCE	123
9.1 WARRANTY	123
9.2 PRODUCT INQUIRY.....	124
9.3 ROUTINE CHECK	124
9.4 PERIODIC CHECK	124
APPENDIX A INVERTER EMC INSTALLATION GUIDE.....	127
A.1 NOISE SUPPRESSION	127
A.1.1 Types of noise.....	127
A.1.2 Noise transmission route	127
A.1.3 Basic method for noise suppression	129
A.2 WIRING REQUIREMENT	130
A.2.1 Requirement for cable laying	130
A.2.2 Requirement for cable cross section area	130
A.2.3 Requirement for shielded cable	130
A.2.4 Installation requirement for shielded cable	130
A.3 GROUNDING	131
A.3.1 Type of grounding	131
A.3.2 Precaution for ground wiring	131
A.4 SURGE ABSORBER INSTALLATION	132
A.5 LEAKAGE CURRENT AND ITS SOLUTION	132
A.5.1 Ground leakage current	133
A.5.2 Cable inter-line leaking	133
A.6 RADIATION SUPPRESSION.....	133
A.7 POWER CABLE FILTER GUIDE	134
A.7.1 Function of power cable filter	134
A.7.2 Precaution for power cable filter installation	135
A.8 INSTALLATION SECTION DIVIDE FOR EMC INVERTER.....	135
A.9 PRECAUTION FOR ELECTRICAL INSTALLATION	137
A.10 EMC STANDARD FULFILLED BY AS320 SERIES ELEVATOR INVERTER.....	138
APPENDIX B FULL LIST OF FUNCTION PARAMETRS, FAULT LIST	139
B.1 FUNCTION PARAMETERS LIST.....	139

B.2 FAULT LIST..... 158

APPENDIX C STANDARD COMPATIBILITY 165

NOTICE TO CUSTOMERS 1

Chapter 1 The Using Notes Of Inverter

The users who are familiar with this product can refer APPENDIX C Quick Operation Guide directly.

This chapter introduces general information of inverter, including inverter voltage levels, adaptable motor capacity, Ooba and etc. It also describes the notices of inverter installation, wiring, operation, maintenance and discard are introduced in detail. It will help to operate this product safely, and extend the service life. Please read this chapter carefully.

1.1 Voltage Level And Adaptable Motor Capacity

AS320 series inverter provides 200V and 400V products. It supports both asynchronous and synchronous motors. Currently it can accept the motor capacity range from 1.1 ~ 75 kW, for any type beyond this scope, please contact engineering center of our company.

1.2 Out Of Box Audit (OOBA)



Please check carefully while opening package: whether there is any sign of transport damage, whether the model, type in the nameplate matches the order requirements. Please contact the manufacturer or supplier for the solution quickly, once any inconformity or items omission discover.

1.3 Description of inverter model

The description of inverter model, see Fig.1.1.

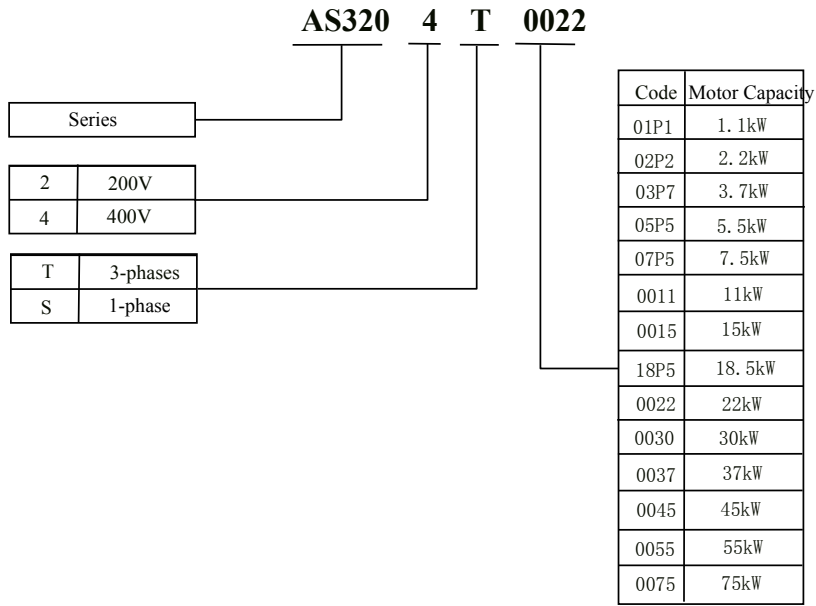

Fig.1.1 The description of inverter model

1.4 Description Of Inverter Nameplate

Inverter nameplate, see Fig.1.2. Nameplate records the model, specification and lot number.

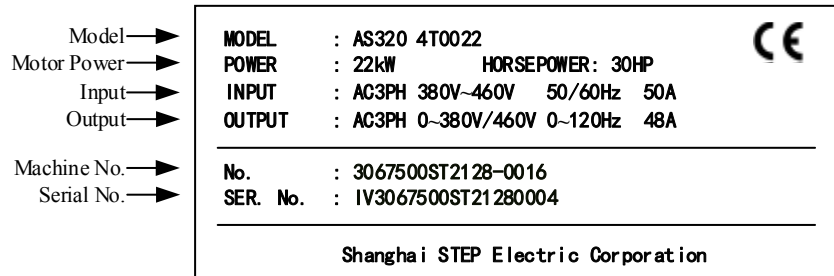

Fig. 1.2 The description of the inverter nameplate

1.5 Safety Precautions

Danger

- ⊙ **Must be installed on metal or other non-inflammable material.**
Or it may cause fire hazard.
- ⊙ **Do not allow to install in surrounding with explosive gas.**
Or it may cause explosion hazard.
- ⊙ **Do not allow to place inflammable material nearby.**
Or it may cause fire hazard.
- ⊙ **Prevent from getting an electric shock.**

Caution

- ⊙ **During carrying, please hold the inverter from the bottom of its case.**
Or it may cause human injury, product damage while falling.
- ⊙ **Consider the load capacity while installing inverter.**
Or it may cause human injury, product damage while falling.
- ⊙ **Do not install in a site near water pipe or have risk of water splashing.**
Or it may cause the damage of inverter.
- ⊙ **Do not fall screws, washers, metal bar or any foreign parts inside inverter.**
Or it may cause fire hazard, damage.

- ⊙ **Ensure to have power supply fully disconnected before wiring.**
Or it may cause electric shock.
- ⊙ **Only certified electrician can handle wiring task.**
Or it may cause electric shock.
- ⊙ **Ensure the protect grounding terminal E to be grounded reliably.**
Or it may cause electric shock.
- ⊙ **Do not mix the input and output terminals in main circuit.**
Or it may cause the inverter damage and have a risk of explosion.
- ⊙ **Do not short connect terminal ⊕1 / ⊕2 and ⊖.**
Or it may have a risk of fire or explosion hazard.
- ⊙ **Ensure to have cap covered before power on.**
Or it may cause electric shock or explosion.
- ⊙ **Ensure not to operate the inverter with wet hands.**
Or it may cause electric shock.

- ◎ **When emergency stop safety loop is connected, a careful wiring check is required afterwards.**Or it may cause hazard.

 **Danger**

- ◎ **For inverter stored more than two years, voltage should be increased gradually through voltage regulator when the power is on.**
Or it may cause electric shock or explosion hazard.
- ◎ **Do not make wrong operation while inverter is running.**
Or it may cause HV electric shock.
- ◎ **Within certain period of time after power off, there is still hazardous HV existing inside the inverter. Do not open covers or touch terminal blocks.**
Or it may cause HV electric shock.
- ◎ **Only trained, authorized professional staff can allow to maintain the product.**
Or it may cause damage to inverter and electric shock.
- ◎ **Maintenance staff must remove all metal articles such as watches, rings before starting. Clothes and tools used must conform the insulation requirement.**
Or it may cause electric shock or explosion.

1.6 Operating notice

Please pay attention to the following while using AS320 series inverter.

1.6.1 Select braking resistor

Elevator has feature of potential energy loading, operating in four quadrant, and can generate power by braking. In this case brake component is required in order to avoid fault of overvoltage and tripping. All AS320 series products are integrated braking component. Only extra braking resistor is required. The specification of the braking resistor see table 1.1.

Table 1.1 AS320 Series Elevator Inverter Braking Resistor Specification

Voltage level	Model	Power Capacity (KW)	Minimum (Ω)	Maximum (Ω)	Recommend (Ω)	Recommend total power of resistor(W)			
						Floor<20		Floor>20	
						Syn-chronous	Asyn-chronous	Syn-chronous	Asyn-chronous
200V	2S01P1	1.1	14.4	117.8	32	500	400	600	500
	2S02P2	2.2	14.4	58.9	32	1000	800	1000	900
	2S03P7	3.7	14.4	35	24	1600	1300	1700	1500
	2T05P5	5.5	14.4	23.6	20	2400	2000	2500	2200
	2T07P5	7.5	10.3	17.3	12	3200	2700	3400	3000
	2T0011	11	7.2	11.8	8	4700	3900	5000	4400
	2T0015	15	4.8	8.6	6	6300	5300	6800	6000
	2T18P5	18.5	3.6	7	4	7800	6500	8400	7400
	2T0022	22	3.6	5.9	4	9300	7700	10000	8800
400V	4T01P1	1.1	26.4	396	100	500	400	500	500
	4T02P2	2.2	26.4	198	100	1000	800	1000	900
	4T03P7	3.7	26.4	117.7	64	1600	1300	1700	1500
	4T05P5	5.5	26.4	79.2	64	2400	2000	2500	2200
	4T07P5	7.5	18.9	58.1	32	3200	2700	3400	3000
	4T0011	11	18.9	39.6	24	4700	3900	5000	4400
	4T0015	15	13.2	29	20	6300	5300	6800	6000
	4T18P5	18.5	13.2	23.5	16	7800	6500	8400	7400
	4T0022	22	13.2	19.8	16	9300	7700	10000	8800
	4T0030	30	6.6	14.5	8	13000	10000	14000	12000
	4T0037	37	6.6	11.8	8	16000	13000	17000	15000
	4T0045	45	4.4	9.7	6	19000	16000	20000	18000
	4T0055	55	4.4	7.9	6	23000	20000	25000	22000
	4T0075	75	4.4	5.8	5	31000	26000	34000	30000

1.6.2 No absorber at output

The output of inverter is pulse wave, if there is any capacitor for factor improvement, or lighting protection VDR installed, it will cause inverter tripping or component damage. By designing it should be taken in the consideration. For example in modernization reconstruction, all capacitors and VDR connected at the output side must be removed.

Schematic diagram shows that output side of inverter can not connect capacitor. See Fig. 1.3.

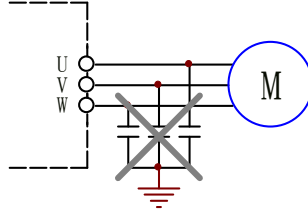

Fig. 1.2 Capacitor can not be connected to the output of inverter

1.6.3 Operating voltage

AS320 series inverter can only work during its designated rating volt range. A voltage regulator is required if the power voltage is inconformity with the rating voltage.

1.6.4 Avoid 2-phases input

3-phase input can not be changed to 2-phase input. Or a fault may occur.

1.6.5 The user application control to output contactor

When output contactor is connected by user application, to ensure output contactor can be opened or closed without current. The contactor should suck before the operating commend sending to motor. And the contactor should release after short delay of stop signal sent.

1.6.6 Altitude vs. descendent rated current

In altitude over 1000m area, rarefied air will cause poor heat radiation of inverter. In this case, to use inverter in descendent rated output current is necessary. Fig 1.4 shows the relationship between descendent rated output current and the altitude.

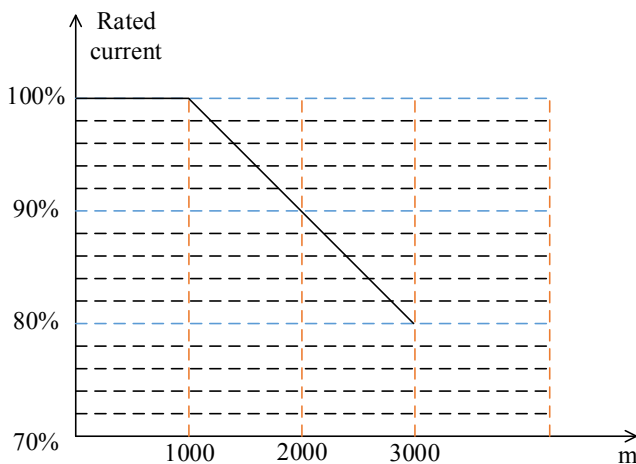

Fig 1.3 Diagram of rated output current vs. altitude

1.6.7 Ambient temperature vs. descendent rating power

The temperature range in normal operation is -10C ~ 45C. When it exceeds 45°C, 10% power decrement for each further 5°C up, to maximum 50C is required.

1.6.8 Synchronous sealing star delay

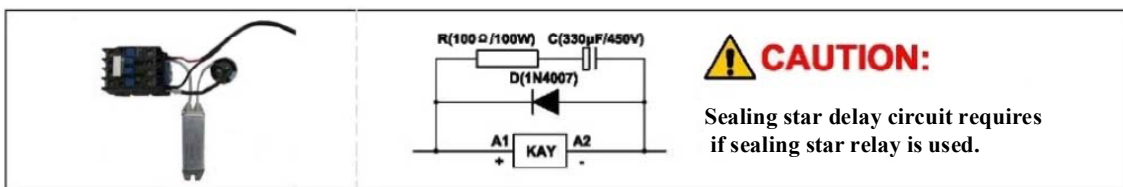

Fig. 1.4 Sign sticker for sealing star delay circuit

1.6.9 Accord with low voltage directive

Our products meet the standard of EN1800-5-1, thus they are in accord with “Low Voltage Directive 2006/95/EC”. Make sure that the whole system meets EC requirement if this inverter is integrated in the whole electrical system as a component.

Please note:

- ①To ensure that machine is grounded, and the ground terminal block is grounded separately
- ②Prohibit to ground inverter at Δ, and use IT power
- ③To ensure that the cabinet is grounded if inverter is installed in it
- ④Use CE certified breaker, electromagnetic contactor and other components. Type B leakage current circuit breaker is required
- ⑤The protection level of this inverter is class 1. And please use it under the conditions as overvoltage Catalogue III. 3, and pollution Degree II.

1.7 Discard as useless notice

A discard as useless inverter needs to be handled as industrial refuse.

1.7.1 Capacitor handling

Electrolytic capacitors in main circuit and printed circuit board may explode while burning. It is prohibited to burn them.

1.7.2 Plastic piece handling

There are many plastic parts in inverter. Burning plastic will produce toxic gas. It is prohibited to burn them.

Chapter 2 Model And Specification

This chapter lists models, specifications and installation dimensions of AS320 series inverter.

2.1 Model

See table 2.1 for the models of AS320 series inverter.

Table 2.1 The models of AS320 Series Elevator Inverter

Model AS320-	Rated Capacity (kVA)	Rated output current (A)	Motor Power (kW)
200V			
2S01P1	2.3	6.0	1.1
2S02P2	4.6	12	2.2
2S03P7	6.9	18	3.7
2T05P5	9.5	25	5.5
2T07P5	12.6	33	7.5
2T0011	17.9	47	11
2T0015	23	60	15
2T18P5	29	75	18.5
2T0022	32	80	22
400V			
4T01P1	2.7	3.5	1.1
4T02P2	4.7	6.2	2.2
4T03P7	6.9	9	3.7
4T05P5	8.5	13	5.5
4T07P5	14	18	7.5
4T0011	18	27	11
4T0015	24	34	15
4T18P5	29	41	18.5
4T0022	34	48	22
4T0030	50	65	30
4T0037	61	80	37
4T0045	74	97	45
4T0055	98	128	55
4T0075	130	165	75

2.2 Technical Indexes and Specifications Of The inverter

Technical Indexes and Specifications of AS320 series elevator inverter, see Table 2.2.

2.2.1 200V Level Inverter Specifications

Table 2.2 200V Level Technical Specifications

		2S01P1	2S02P2	2S03P7	2T05P5	2T07P5	2T0011	2T0015	2T18P5	2T0022
Max matching motor power capacity (kW)		1.1	2.2	3.7	5.5	7.5	11	15	18.5	22
Rated output	Rated output capacity (kVA)	2.3	4.6	6.9	9.5	12.6	17.9	23	29	32
	Rated output current (A)	6.0	12	18	25	33	47	60	75	85
	Max output voltage (V)	3-phase 220~240 (match with input voltage)								
Input power	Phase, Voltage, Frequency	≤3.7KW, single-phase or 3-phase; >3.7KW, 3-phase, 200~240V, 50/60Hz								
	Permissible Frequency Fluctuation	-5%~+5%								
	Endurance capacity of instantaneous voltage drop	Keep running at AC180V or above; Activate under-voltage protection after 15ms from the moment when the rated input voltage decline under AC180V.								

2.2.2 400V Level Inverter Specifications

Table 2.3 400V Level Technical Specifications

		4T0-1P1	4T0-2P2	4T0-3P7	4T0-5P5	4T0-7P5	4T0-011	4T0-015	4T1-8P5	4T0-022	4T0-030	4T0-037	4T0-045	4T0-055	4T0-075
Max matching motor power capacity (kW)		1.1	2.2	3.7	5.5	7.5	11	15	18.5	22	30	37	45	55	75
Rated output	Rated output capacity (kVA)	3.5	4.7	6.9	8.5	14	18	24	29	34	50	61	74	98	130
	Rated output current (A)	2.8	6.2	9	13	18	27	34	41	48	65	80	97	128	165
	Max output voltage (V)	3-phase 380/400/415/440/460V (match with input voltage)													
Input power	Phase, Voltage, Frequency	3-phase 380/400/415/440/460V 50/60Hz													
	Permissible Frequency Fluctuation	-5%~+5%													
	Endurance capacity of instantaneous voltage drop	Keep running at AC300V or above; Activate under-voltage protection after 15ms from the moment when the rated input voltage decline under AC300V.													

2.2.3 General indexes and specifications

Table 2.4 The general indexes and specifications of AS320 series

AS320 Series		The general indexes and specifications
Control Characteristics	Control Mode	PG card vector control, Voltage Vector V/F , Torque control
	Starting torque	150% at 0Hz (PG card vector control), 120% at 0.5Hz(Voltage vector V/F), 150% at 0.5Hz(Open loop vector)
	Speed Control Range	1:1000 (with PG Vector control), 1:200(without PG Vector control)
	Speed Control Accuracy	±0.02%
	Torque Limit	Yes (parameter setting)
	Torque Accuracy	±5%
	Frequency Control Range	0~120Hz

	Frequency Accuracy (Temp. Fluctuation)	$\pm 0.01\%$ (digital command), $\pm 0.1\%$ (analog command)
	Frequency Resolution	0.01Hz (digital command), $\pm 0.06\text{Hz}/120\text{Hz}$ (analog command 11bit + no sign)
	Output Frequency Resolution (min, calculated increment)	0.01Hz
	Overload Capacity	150% at 0Hz , 160% at $< 3\text{Hz}$, 200% at $> 3\text{Hz}$
	Brake Torque	150% (external braking resistor), build-in braking unit
	Acceleration/Deceleration Time	0.01~600s
	Carrier Frequency	200V level: 2~16kHz 400V level: 2~8 kHz
	Speed Setting	Digital, analog, panel
	DC Bus Cable Running in Low Voltage	By power failure, elevator stops in nearest level in slow mode using its own batteries
PG Card Signal	PG Card Power	5V, or 12V,300mA
	PG Card Signal	Open collector, Push-pull, Differential, SIN/COS、 Endata absolute value
	PG Card Crossover Frequency Output	OA, OB orthogonality, coefficient of crossover frequency 1~128
Control I/O Signal	Analog Voltage Input	2 way, -10~+10VDC, accuracy 0.1%
	Analog Voltage Output	2 way, -10~+10VDC, accuracy 0.1%
	Opto-coupler Isolating Input	8 way, user defines input function
	Open collector Output	4 way, user defines output function
	Programmable Relay Output	2 way, NO, NC dual contacts. Contact capacity: resistance, 5A 250VAC or 5A 30VDC; Definable output function
	RS485 Communication Port	1 way
	RS232 Communication Port	1 way, for operator or PC
Protection Function	Motor Overload Protection	Set parameter to create motor protective curve
	Inverter Overload	160%, >5s at $< 3\text{Hz}$; 185%, >10s at $> 3\text{Hz}$
	Short Protection	Protect inverter from overcurrent due to the short of any two phase (wire) at output side, without branch short circuit protection.
	Input Open Phase Protection in Operation	In case of open phase input in operation, output cuts off to protect inverter
	Output Open Phase Protection in Operation	In case of open phase output in operation, output cuts off to protect inverter
	Overvoltage Threshold	Bus Voltage: 410V(200V series), 810V(400V series)
	Undervoltage Threshold	Bus Voltage 180V(200V series), 380V(400V series)

	Instant Power failure Compensation	Protect after Over 15ms
	Radiator Overheat	Protect by thermal resistor, without motor overheat protection.
	Stallout Protection	Stallout protection triggers if operation speed offsets more than 30% of the rated speed.
	Fault of Pulse Encoder	PG disconnected
	Brake Unit Protection	Automatically check out abnormal brake unit, and protect it.
	Module Protection	Overcurrent, short connection, overheat protection
	Current Censor Protection	Self-check at power on
	Reversed Speed Protection	Detect by encoder
	I ² t Protection	Detect by 3-phase current
	Overvoltage Input Protection	Stopping check when voltage greater than 725V for 400V inverter, 360V for 200V inverter
	Output Ground Protection	If any phase shorts to ground during in operation, output cuts off to protect inverter
	Output Unbalance Protection	If any unbalance of 3-phase current detected during in operation, output cuts off to protect inverter
	Brake Resistor Short Protection	Detected during braking
	Encoder Interference	Evaluate degree of interference and alarm
	EEPROM Fault	Self-check at power on
Display	LCD Display	All levels of the menu
Environment	Ambient Temp.	-10~+45℃
	Humidity	Below 95%RH (no dew formed)
	Storage Temp.	-20~+60℃ (short term during transport)
	Operation Field	In-door (no corrosive gas, dust free)
	Altitude	Below 1000m
Structure	Level of Protection	IP20
	Cooling Method	Forced air cooling
Installation		In cabinet

2.3 Mounting dimension and weight of the inverter

Installation dimensions and weight of inverter, see Fig 2.1 and Table 2.3.

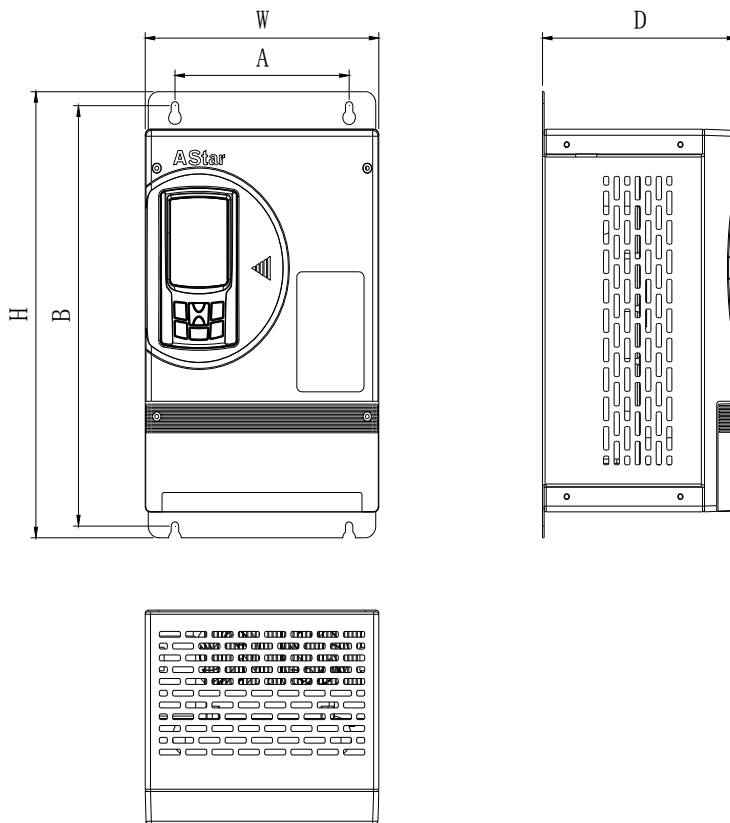

Fig 2.1 Inverter installation dimension

Table 2.3 AS320 series inverter installation dimension and weight

Model AS320-	A (mm)	B (mm)	H (mm)	W (mm)	D (mm)	Installing Diameter Φ(mm)	Installation			Tightening torque(Nm)	Weight (kg)
							Bolt	Nut	Washer		
2S01P1	100	288.5	300	160	166	5.0	4M4	4M4	4Φ4	2	4.5
2S02P2											
2S03P7											
2T05P5	165.5	357	379	222	185	7.0	4M6	4M6	4Φ6	3	8.2
2T07P5											
2T0011											
2T0015	165	440	465	254	261	7.0	4M6	4M6	4Φ6	3	10.3
2T18P5											
2T0022											
4T02P2	100	288.5	300	160	166	5.0	4M4	4M4	4Φ4	2	4.5
4T03P7											
4T05P5											
4T07P5	165.5	357	379	222	192	7.0	4M6	4M6	4Φ6	3	8.2
4T0011											
4T0015											
4T18P5	165.5	392	414	232	192	7.0	4M6	4M6	4Φ6	3	10.3
4T0022											
4T0030											
4T0037	200	512	530	330	290	9.0	4M8	4M8	4Φ8	6	30
4T0045										9	
4T0055										14	
4T0075	200	587	610	330	310	10.0	4M10	4M10	4Φ10	14	42
4T0075	320	718	750	430	351	13.0	4M13	4M13	4Φ13	29	79.5

2.4 Operator dimension

Dimensions of operator, see Fig 2.2.

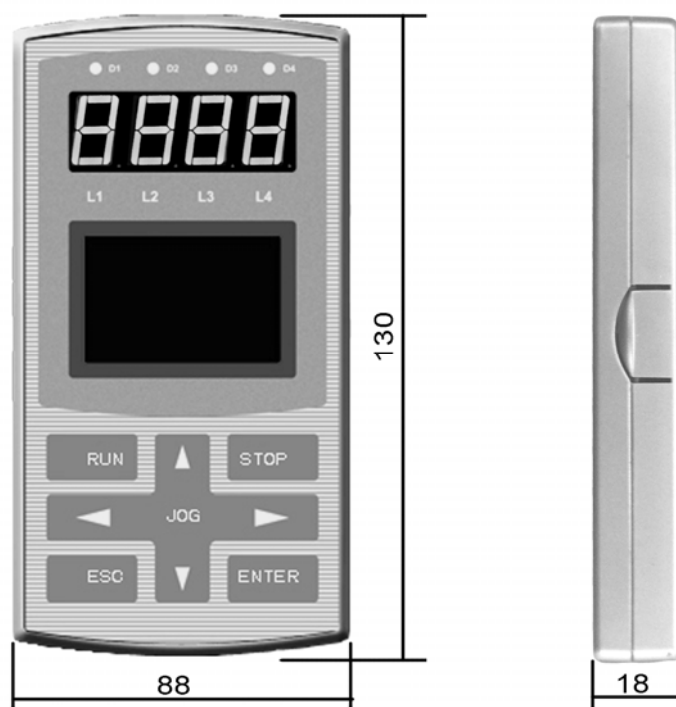



Fig 2.2 The dimension of the inverter Operator

Chapter 3 Mechanical Installation Of The Inverter

This chapter describes inverter installation requirements, notices, front panel mounting and dismounting.

3.1 Installed location

 Danger
<ul style="list-style-type: none"> ⊙ Must be installed on metal or other non-inflammable material. Or it may cause fire hazard. ⊙ Do not allow to place inflammable material nearby. Or it may cause fire hazard. ⊙ Do not allow to install in surrounding with explosive gas. Or it may cause explosion hazard. ⊙ Cabinet installed inverter must conform to EN50178 standard.

 Caution
<ul style="list-style-type: none"> ⊙ Do not lift the inverter at operation panel or cover by carrying Or it may cause inverter falling and damage ⊙ Consider the load capacity of the platform while installing inverter Or it may cause inverter falling and damage ⊙ Do not install in a site having risk of water splashing Or it may cause inverter damage ⊙ Do not fall screws, washers, metal bar or any foreign parts inside inverter Or it may cause explosion hazard, damage ⊙ Do not install and operate, if inverter damaged or missing parts Or it may cause damage ⊙ Avoid to install a place directly under sun light Or it may cause inverter overheating, and the risk of accident.

Following conditions need to be met for the site that inverter installed:

- 1) Clean place without oil mist, dust, or to install in a dust proof, totally closed cabinet;
- 2) Place which can prevent metal powder, oil, water into inverter;
- 3) Place without flammable materials such as wood;
- 4) Place without radioactive substances;

- 5) Place without hazardous gas, liquid;
- 6) Place with minor vibration;
- 7) Place with less salinity;
- 8) Place without direct sunlight;
- 9) Place with less temperature rising.

Please install cooling fan or air conditioner when inverter is installed in a closed cabinet to maintain the temperature below 40°C.

3.2 The installation direction and space requirements of the inverter

In order to maintain cooling effectiveness, inverter needs to be installed in a well ventilated place. It is normally installed vertically. Space requirements for installation, see Fig. 3.1.

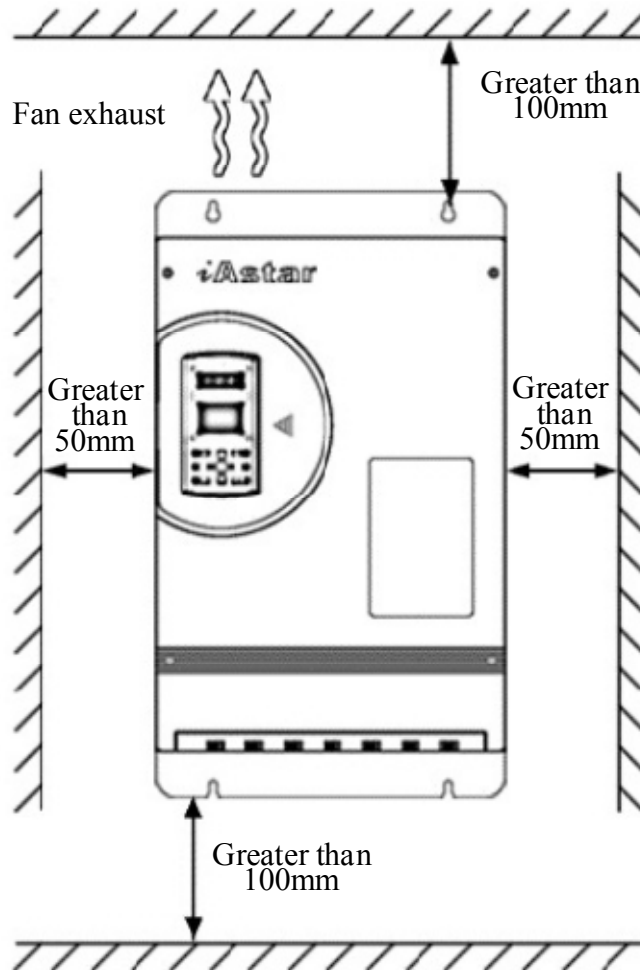

Fig. 3.1 Inverter installation space

3.3 Inverter installation

Installation procedures:

- 1) Secure 4 installing holes on inverter, refer to Fig. 2.1 “AS320 series inverter installation dimension and weight” and mount top upper screws first. Note, do not tighten screws and leave a few millimeter gap.
- 2) Hang inverter on mounted screws by matching two pear shaped holes at the upper of inverter
- 3) Mount two bottom screws and tighten all four screws.



Important

Fasteners must have anti-vibration parts such as spring washer.

All four mounting screws must be securely tightened.

Inverter installation procedure, see Fig. 3.2.

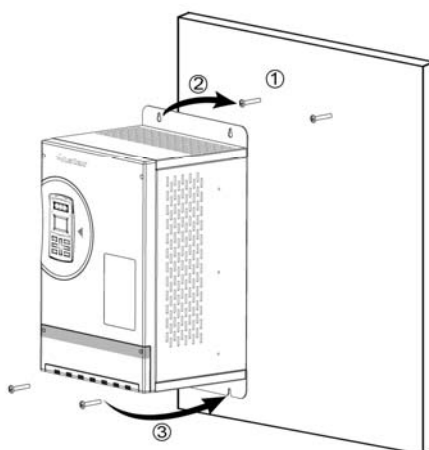

Fig. 3.2 Installation procedure

3.4 Disassembly/assembly inverter shell

3.4.1 Overall shape, and the names of its parts

Overall shape, and the names of its parts, see Fig. 3.3.

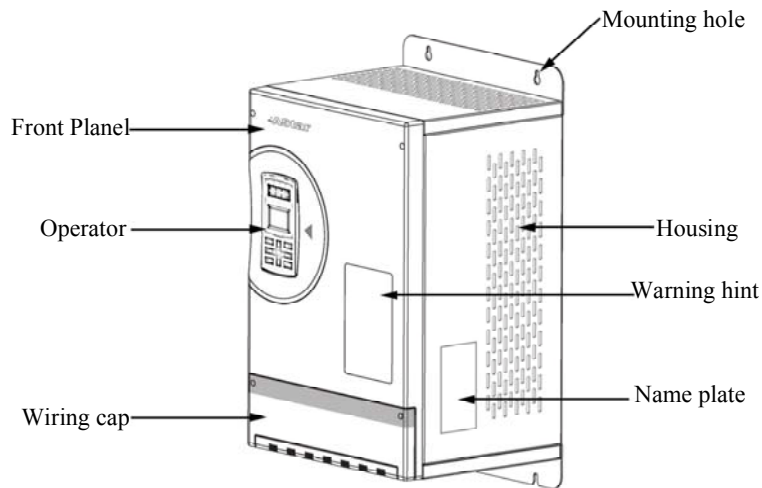

Fig. 3.3 View of inverter shape, and the names of its parts

3.4.2 Connect/disconnect the operator

(1) Disconnect the operator

1) Press latch springs at both sides of operator simultaneously to unhook the operator from the front panel, and then the operator can be removed from inverter.

2) A cable at the back of operator connecting to inverter needs to be unplugged. Note, do not pull directly on the cable, it may damage the connection.

Connect and disconnect operator, see Fig. 3.4



Fig. 3.4 Disconnect operator

(2) Connect operator

Plug the cable into the socket at the back of operator first, then slide one side of latch into the groove of front panel, press operator against the panel until a “Click” sound heard. Both latches are locked properly.

3.4.3 Open/close wiring cap

Wiring cap needs to be open when connecting main circuit loop or take off front panel.

(1) Open wiring cap:

- 1) Loose two screws on wiring cap;
 - 2) Open wiring cap downward.
- Open wiring cap, see Fig. 3.5.

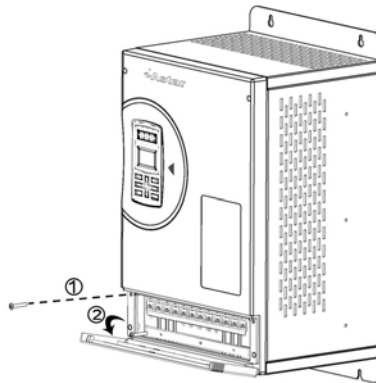

Fig. 3.5 Open wiring cap

(2) Close wiring cap

Operate open wiring cap procedure reversely to close it, tighten two thumb screws.

3.4.4 Mount/dismount front panel

Front panel needs to be dismantled when controlling loop is wired. For the convenience to wire the main loop the front panel may also be removed.

(1) Dismount front panel

Procedures of dismantling the front panel.

- 1) Remove operator. Refer to chapter 3, 3.4.2 Connect/Disconnect the operator;
- 2) Open wiring cap. Refer to chapter 3, 3.4.3 Open/Close wiring cap;
- 3) Loose two screws at top of panel, two screws inside wiring cap compartment, and then the front panel can be removed.

The Operation to remove the front panel, see Fig. 3.6.

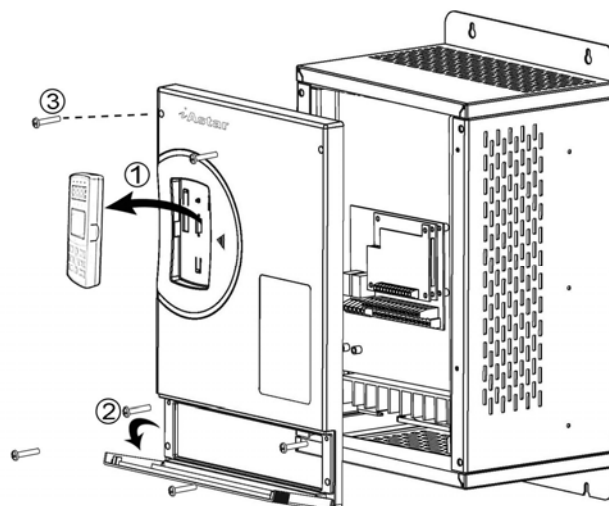

Fig. 3.6 Remove the front panel

(2) Mount front panel

Mount front panel in a reversed order of dismantling the front panel.

Chapter 4 The Wiring Of The Inverter

This chapter introduces the wire connection in details in inverter and its peripheral equipments, inverter terminal blocks, main circuit looping, controlling circuit looping and PG card.

Danger

- ⊙ **Ensure to have power supply fully disconnected before wiring.**
Or it may cause electric shock.
- ⊙ **Only the certified electrician can handle wiring task.**
Or it may cause electric shock.
- ⊙ **Ensure the protect grounding terminal E to be grounded reliably.**
Or it may cause electric shock.
- ⊙ **Don't touch terminal block by hand directly, don't connect the output cable to the inverter enclose.**
Or it may cause electric shock.
- ⊙ **Don't connect power supply to output terminal U, V, W.**
Or it may damage inverter.
- ⊙ **Do not short connect the terminal ⊕1 / ⊕2 to ⊖.**
Or it may have a risk of explosion hazard.

Caution

- ⊙ **Ensure the consistency between the voltage of power supply in AC main circuit and rated voltage.**
Or it may cause human injury and fire hazard.
- ⊙ **Connect braking resistor correctly referring to wiring diagram.**
Or it may cause fire hazard.
- ⊙ **Secure fastenedly connect the main circuit to the wiring cables or to the wire crimping terminal.**
Or it may damage inverter.
- ⊙ **Avoid to be electric shocked.**

4.1 Connect inverter to peripherals

4.1.1 Connection diagram between inverter and peripherals

Connection diagram between the inverter and its peripheral equipments. See Fig. 4.1.

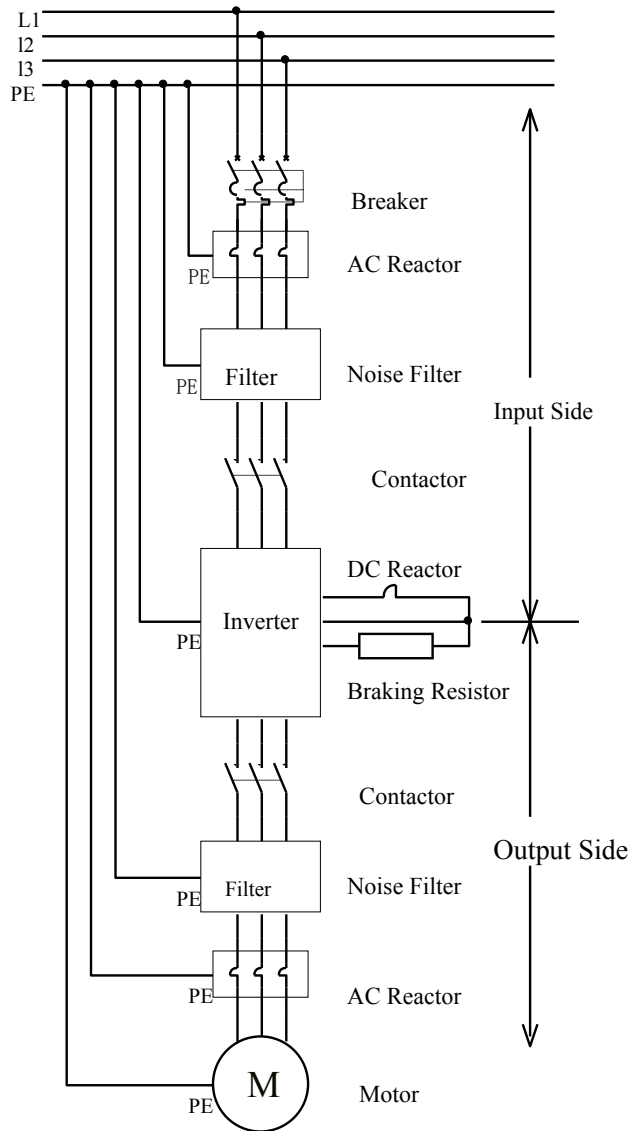

Fig. 4.1 The connection between the inverter and its peripheral equipments

Note: Sample drawing shows a 3-phase input power supply.

4.1.2 Connect inverter to peripherals

4.1.2.1 Input power connection



Don't operate inverter beyond the rated input voltage range.

Overvoltage may damage inverter permanently.

The technical requirements for the input power are as follows:

Table 4.1 The technical requirements for the input power

The connection technical requirements for power input (Main circuit)	
Input Voltage	200V:200~240V AC≤3.7KW, single-phase or 3-phase; >3.7KW 3-phase, -15%~+10% 400V: 380/400/415/440/460V AC 3 phase, -15%~+10%
Short Current (IEC60909 Standard)	If incoming cable is properly protected by fuse, the max permissible short current in 1 second is 100KA
Frequency	50/60 ± 5% Hz
Cable Temperature	It's permissible that the inverter works at 90°C for a long-term period.

(1) Input protection

Input protection includes breaker, fuse and emergency stop.

(2) Breaker

Inverter doesn't carry breaker by itself. Therefore breaker must be installed between AC input power supply and the inverter. Ensure the following notice of the breaker:

◎ Type selection must conform with the applied safety regulation, including (but not limit to) national and local electric regulation.

◎ During installation and maintenance to the inverter, breaker must ensure to stay at open position and be locked.

Breaker doesn't allow to control to start or stop the motor. Motor is controlled by operator keypad or I/O terminal command.

Capacity of selected breaker should be 1.5~2 times of rated inverter current.

Breaker time response character should correspond with the inverter overheat protection character (over 150% of rated output current for more than 1minute).

(3) Fuse cutout

Terminal user must provide loop protection device, which is consistent with the national and local electric laws and regulations. The table below introduces recommended fuse cutout types, it provides short protection for inverter incoming cable.

Table 4.2 The recommended fuse cutout types

AS320-	Input Current(A)	Main Fuse Cutout	
		UL Grade T (A)	Bussmann Type
2T05P5	28	60	FWH-60A
2T07P5	37	100	FWH-100A
2T0011	52	100	FWH-100A
2T0015	58	150	FWH-150A
2T18P5	73	200	FWH-200A
2T0022	82	200	FWH-200A
4T02P2	7.2	40	FWH-40A
4T03P7	10	40	FWH-40A
4T05P5	14	40	FWH-40A
4T07P5	19	40	FWH-40A
4T0011	28	80	FWH-80A
4T0015	35	80	FWH-80A
4T18P5	42	125	FWH-125A
4T0022	49	125	FWH-125A
4T0030	66	125	FWH-125A
4T0037	81	150	FWH-150A
4T0045	97	150	FWH-150A
4T0055	129	200	FWH-200A
4T0075	166	200	FWH-200A

(4) Input Fuse

To meet the UL standard, please use the fuse shown in the table below at the input side of inverter.

◎ When using quick-acting fuse at J, T, or CC levels, please select the fuse whose capacity is 300% of the rated inverter input current.

◎ When using slow-acting fuse at J, T, or CC level, please select the fuse which capacity is 175% of the rated inverter input current.

◎ When using slow-acting fuse at RK5 level, please select the fuse whose capacity is 225% of the rated inverter input current.

(4) Short-circuit tolerance

The UL short-circuit experiment runs under the conditions that using the fuses that shown above, the power short-circuit is at or under 5000 ampere, and the power supply voltage is at or under 480V.

(5) Emergency stop

General design and installation must include emergency stop device and other necessary safety equipments. To control motor by operator keypad operation, or I/O commend can't guarantee:

- ⊙ Emergency motor stop;
- ⊙ Separate inverter from hazardous voltage.

4.1.2.2 Input power cable/connection

Input cable can be any one of followings:

- ⊙ 4 core cable (3 phase and ground protection);
- ⊙ 4 core insulated cable installed in conduit.

To select proper power cable according to the local safety laws and regulations, input voltage level and inverter load current. In any circumstances, the size of the conducting wire must smaller than the defined maximum limit value defined (refer to chapter 4, 4.5.4 The conducting wire specification of tht control circuit wire requirement). Table below lists types of copper cables under different load currents. Recommended types are only suitable when the situation meets the top part of the table. Aluminum cable is not recommended.

Table 4.3 Relevant standards of IEC and NEC requirements for input power cables

IEC	NEC
Based on: ⊙ EN 60204-1 and IEC 60364-5-2/2001 standard; ⊙ PVC Insulation; ⊙ Ambient temperature at 30 °C; ⊙ Surface temperature at 70 °C; ⊙ Copper net shielded symmetrical cable; ⊙ No more than 9 cables layed side by side in a same cable tray compartment.	Based on: ⊙ For copper cable , see NEC Table 310-16; ⊙ Cable insulation at 90 °C; ⊙ Ambient temperature at 40 °C; ⊙ No more than 3 current-carrying cables in the same trunking, the cable trench, or the buried cables. ⊙ Copper net shielded copper core cable

Table 4.4 The corresponding parameters of the copper core cable

Copper cable (mm ²)	Max Carry Current (A)	Copper cable Model (AWG/kcmil)	Max Carry Current (A)
3x1.5	14	14	22.8
3x2.5	20	12	27.3
3x4	27	10	36.4
3x6	34	8	50.1
3x10	47	6	68.3
3x16	62	4	86.5
3x25	79	3	100

3x35	98	2	118
3x50	119	1	137
3x70	153	1/0	155
3x95	186	2/0	178

4.1.2.3 Grounding connection of input power cable

To ensure human safety, correct operation and to reduce electromagnetic radiation, inverter and motor must be grounded at their installed place.

- ◎ The diameter of conductor must be meet the requirements of the safety laws and regulations.
- ◎ The shielding layer of power cable must be connected to PE terminal of inverter to meet the safety guideline
- ◎ Only when the specifications of the power cable shielding layer meet safety requirements, can the shieldling layer of power cable be used as ground connection
- ◎ Don't connect terminal blocks in series when multi inverters installed

4.1.2.4 Output power cable/connection

(1) Motor connection



Danger

Never connecting power supply cable to output terminal (U, V and W) of inverter directly. Connecting incoming power supply cable to output terminal will cause inverter damaged permanently.



Caution

Don't connecting motor whose rated voltage is half or less than the inverter rated input voltage.



Caution

Before the withstand voltage test or insulation resistance test for the motor and the motor cables, the connecting between inverter and motor cable must be disconnected.

Don't do above mentioned tests for inverter.

(2) Technical specification for motor connection

Table 4.5 Output power (Motor connection technical specification)

Technical specification for output power (motor)	
Output Voltage	0 ~ input voltage, symmetric 3-phase
Current	see Chapter 2, 2.2 Technical Indexes and Specifications Of The inverter
Switch frequency	Allow to set: 200V: 2 ~ 16 kHz 400V: 2~8kHz
Rated cable temperature	Allow long term working at 90 °C
Length of motor cable vs. switch frequency	See Chapter 4, 4.4.4 Relationship between length of wire and carrier frequency

(3) Grounding and wiring

Motor cable shielding:

Motor cable requires to be shielded by wire conduit, armored cable or shielded cable.

1) Wire conduit

①Each end point of wire conduit must install a grounded bridging;

②Wire conduit needs to be fixed on housing

③Laying an individual conduit for motor cable only. (separate input power cable and control cable)

④One separated conduit for each inverter

2) Armored cable

- ① Each end point of wire conduit must install a grounded bridging;
- ② To use cable having 6 wires (3 power lines, 3 grounding lines). Type MC continuous corrugated Aluminum armored cable with symmetric grounding lines;
- ③ Metal-clay motor cable can share one cable tray with input power cable. But it can't share with control cable.

3) Shielded cable

Recommend to use symmetric PE conductor cable certified by CE or C-Tick.

(4) Grounding

See above "Grounding connection of input power cable".

Table 4.6 The recommended wire size of each power

Model I: AS320-	Europe and China			North America			Tightening torque Nm (lb,in)
	Connectable wire size mm2	Recommended wire size mm2	Connectable ground wire size mm2	Connectable wire size AWG,kcmil	Recommended wire size AWG,kcmil	Connectable ground wire size (AWG),kcmil	
2T05P5	6~16	6	10	8~6	8	8	2(17.7)
2T07P5	10~16	10	10	8~6	8	8	2(17.7)
2T0011	16	16	10	6	6	8	2(17.7)
2T0015	25~50	25	10	4~1	4	8	3(26.9)
2T18P5	35~50	35	10	3~1	3	8	3(26.9)
2T0022	35~50	35	16	2~1	2	6	3(26.9)
4T01P1	1.5~10	2.5	2.5	14-8	14	8	2(17.7)
4T02P2	1.5~10	2.5	2.5	14-8	14	8	2(17.7)
4T03P7	2.5~10	2.5	2.5	14-8	14	8	2(17.7)
4T05P5	2.5~10	4	4	14-8	12	8	2(17.7)
4T07P5	6~10	6	6	10-8	10	8	2.3 / (20)
4T0011	6~10	6	6	10-8	8	8	2.3 / (20)
4T0015	10~25	10	10	8-4	6	8	2.8 / (25.5)
4T18P5	16~25	16	10	6-4	6	8	2.8 / (25.5)
4T0022	16~25	16	10	6-4	4	8	2.8 / (25.5)
4T0030	25~35	25	16	4-2	3	6	6 / (53.1)
4T0037	25~35	35	25	4-2	2	4	6 / (53.1)
4T0045	50~70	50	25	2-2/0	1	4	6 / (53.1)
4T0055	70~95	70	25	1/0-2/0	2/0	4	6 / (53.1)
4T0075	95~120	95	35	3/0-250	4/0	2	10 / (88.5)

4.1.2.5 AC reactor at input side

Select input side AC reactor to improve input side power factor and reduce higher harmonic current.

4.1.2.6 Interference filter at input side

Select interference filter at input side to suppress high frequency noise caused by inverter power supply cable.

4.1.2.7 Contactor at input side

To protect power supply, or prevent fault expanding, on/off of contactor at input side is used to control inverter power supply.

Don't use it to control motor to start or stop.

4.1.2.8 Contactor at output side

In order to meet Chinese National Elevator Safety Standard GB7588-2003, no current through motor by stopping, contactor is installed at output side.

4.1.2.9 Interference filter at output side

Select interference filter at output side to suppress inverter produced interference noise and conductor current leakage.

4.1.2.10 AC reactor at output side

Select AC reactor at output side to suppress inverter RF interference

When connecting cable between inverter and motor is too long (>20m), AC reactor at output side can prevent inverter over-current caused by distributed capacitance of cable.

4.1.2.11 DC reactor

Select DC reactor to improve power factor.

Chapter 5 Operator

Operator is the basic tool to operate inverter. It is used to display operating status and fault code, and also set all kinds of parameters. This chapter will describe how to use the operator in details.

5.1 Function for individual parts

The parts of operator and their name, function, see Fig. 5.1

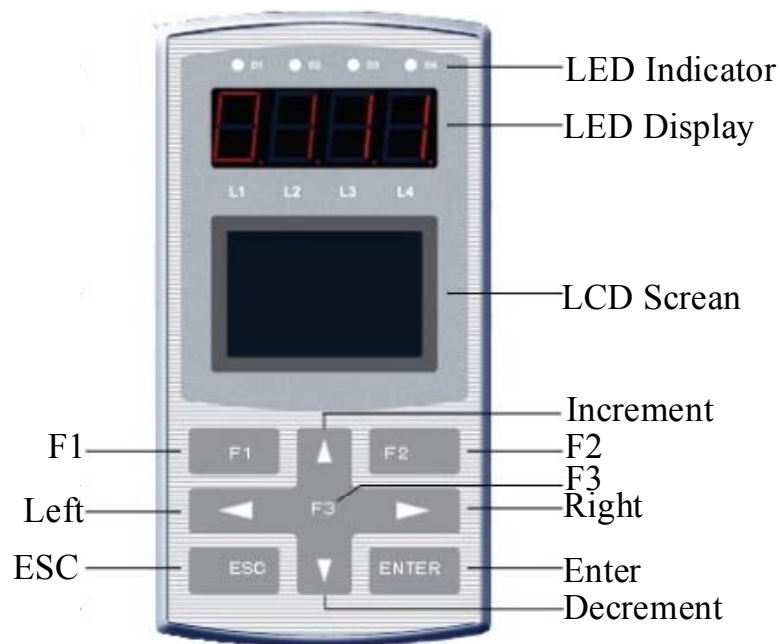

Table 5.1 The names and functions of the parts of the operator

5.1.1 LED indicator

On top of operator have 4 LED indicator, there are D1 (Operating), D2 (Up/Down), D3 (Loc/Remote) and D4 (Fault). These indicators show the elevator status. Indicators versus elevator status, see Table 5.1

Table 5.1 Elevation status indication

Status	D1 (Operate)	D2 (Up/Down)	D3 (LOC/REMOTE)	D4 (Fault)
Up	On	On	Off	Off
Down	On	Off	Off	Off
Fault/Warning	Off	—	—	Flashing
Panel operation	On	On/off	On	Off

5.1.2 LED Digital tube

There are 4 LED digital tubes below the indicators and displaying real time motor speed at the default interface. The content of display can be changed by selecting different parameters.









5.1.3 LCD display

In middle of operator you can find a LCD screen. This is the main screen to display and set the parameter of the inverter, and to view the fault code of the inverter.

5.1.4 Keyboard

There are 9 keys at lower part of operator. Function of those keys, see Table 5.2

Table 5.2 Key function

Key	Name	Function
	Right	In 【Function Select】 mode: To select the next function group; In 【Parameter setting】 mode: To move the cursor to the right;
	Left	In 【Function Select】 mode: To select the previous function group; In 【Parameter setting】 mode: To move the cursor to the left;
	Increment	In 【Function Select】 mode: To select the previous function code; In 【Parameter setting】 mode: To increase the value;
	Decrement	In 【Function Select】 mode: To select the next function code; In 【Parameter setting】 mode: To decrease the value;
	Enter	In 【Monitoring】 mode: To enter the function selecting interface; In 【Function Select】 mode: To enter the selected function interface;
	ESC	In 【Function Select】 mode: back to 【Monitoring】 mode; In all operational sites: beck to 【Function Select】 mode.
	F1	In 【Monitoring】 mode: To reduce the screen brightness; In LOCAL sate: “RUN” function;
	F2	In 【Monitoring】 mode: To increase the screen brightness; In LOCAL sate: “STOP” function;
	F3	Operation mode switch between operator (LOCAL) and control circuit terminal (REMOTE).

5.2 Operation

5.2.1 Display after power on

Screen shows “Monitoring” state 5 seconds after power on. The screen default displays the current reference speed (Vref), feedback speed (Vfbk) and current states (Irms)

5.2.2 “Monitor State” in detail





“Monitoring” interface can be switched by pressing  , or   in “Monitoring” state. 10 real time data of elevator operation are displayed in screen by default. These data is for display only but can't be modified.

Table 5.3 Comparison table for default operation data

Display	Name	Explanation	Range	Unit	Factory Default	Remarks
Vref	Speed reference	Display reference speed for motor	×	rpm	×	
Vfbk	Feedback speed	Display feedback speed of motor	×	rpm	×	
Vdev	Speed deviation	Display deviation of speed reference and feedback speed	×	rpm	×	
Irms	Output current	Display output current	×	A	×	
Torq	Output torque	Display output torque	×	%	×	
Tzero	Zero servo torque	Display zero servo torque at starting	×	%	×	
Udc	DC Bus voltage	Display DC voltage of inverter main circuit	×	V	×	
Uout	Output voltage	Display inverter output voltage	×	V	×	
A10	A0 input voltage	Display input voltage of inverter analog input 0 (A0)	×	V	×	
A11	A1 input voltage	Display input voltage of inverter analog input 1 (A1)	×	V	×	
A12	A2 input current	Display input current of inverter analog input 2 (A2)	×	mA	×	
DI	Input X0-X7	Display the input status of terminals X0-X7, as “XXXXXXXX”, where “X” = 0, indicating no input, “X” = 1, indicating input	×	×	×	
DO	Output Y0-Y3 and K1、K2	Display the output status of terminals Y0-Y3, K1, K2, as “XXXXXX”, where “X” = 0, indicating no input, “X” = 1, indicating input	×	×	×	

5.2.3 “Control Panel”



To press **F3** in “Monitoring” interface can switch two modes between “Monitoring” and “Control Panel”. In “Control Panel” mode LED indicator D3 will be on. To press **F1** at that time may control inverter into operation state, LED indicator D1 in operator will be on. Inverter enters in stop state by pressing **F2**, LED indicator D1 will be off. To press  and  in “Control Panel” interface can switch the monitored contents. In this interface there are 2 panel adjustable parameters and 4 real time operation data. Panel adjustable speed (Vref) and elevator moving direction (Vdir) can be modified, other 4 data are displayed only but can't be modified.

Table 5.4 Comparison table for control panel data

Display	Name	Explanation	Range	Unit	Factory Default	Remarks
Vref	Panel controlled speed	Set speed reference in panel operation	0.00~50.00	Hz	5.00	
Vfbk	Feedback speed	Display motor feedback speed	×	Hz	×	
Irms	Output current	Display output current	×	A	×	
Vdir	Elevator moving direction	Set elevator up or down direction	0~1	×	1	
Udc	DC Bus voltage	Display DC voltage of inverter main circuit	×	V	×	
Uout	Output voltage	Display inverter output voltage	×	V	×	













5.2.4 Operation mode

Operator has 4 operating modes. They are **【Parameter Setting】**, **【Motor Tuning】**, **【Fault Check】** and **【Parameter Processing】**. In any monitoring interface, press **ENTER** can enter into following “Function Select” interface:





- * 1 : parameter setting
- 2: motor tuning
- 3: fault check
- 4: parameter processing

5.2.4.1 **【Parameter Setting】**

Parameters are modified in **【Parameter Setting】** mode. The setting range of parameter refers to chapter 6.

In **【Parameter Setting】** mode, to select parameter group by pressing  or , select parameter code by pressing  or . Press  to confirm the parameter to be modified. A cursor that indicates the position to be modified is displayed on selected parameter. Press  or  to move the cursor and change the modified position, press  or  to increase/decrease the modified value. Then press  to confirm the modification, modification is invalid if  is not pressed. Press  and return to previous menu.







5.2.4.2 【Motor Tuning】

In **【Motor Tuning】** mode, the parameters for motor (asynchronous) and encoder phase angle (sync. Motor) can be retrieved manually by self-learning. Self-learning mode can be selected by modifying X value in ATun = X. Press , a cursor is displayed on the parameter to be modified. press  or  to select self-learning mode. Then press  to confirm. There are 7 self-learning modes. They are:

- 0: normal operation
- 1: static encoder self-learning
- 2: encoder calibration
- 3: end of encoder self-learning
- 4: static motor self-learning
- 5: dynamic motor self-learning
- 6: static motor advanced learning
- 7: dynamic encoder self-learning

Press  and return to previous menu.

5.2.4.3 【Fault Check】



In **【Fault Check】** mode, records of voltage, current, speed reference, feedback speed and content for latest 8 faults are displayed. In main interface, press  to display ER0=X, then press  or  and display changes from ER0 to ER7. ER0 is the latest fault, ER7 is the earliest one. X stands for the fault code in current fault index. The explanation of this fault is displayed underneath at the same time. Press on more time  in fault code display screen, current DC Bus voltage (Ude), output current (Irms), speed reference (Vref) and feedback speed (Vfbk) are displayed. Press  again and return to fault code display screen. Press  and

return to previous menu.

5.2.4.4 【Parameter Processing】

In 【Parameter Processing】 mode, parameter can be uploaded, downloaded, initialized, cleared. To select proper operation mode by modifying X value in Init = X.

Press , a cursor is displayed on the parameter to be modified in position X. press

 or  to select proper operation mode. Then press  to confirm. There are 4 parameter processing modes. They are:

- 1: upload parameter to operator
- 2: download parameter to inverter
- 7: parameter reset
- 8: fault reset

Press  and return to previous menu.

5.3 Fault indication

When inverter has fault, fault indicator D4 on top of operator will blink. LED tube light will display real-time fault code. Table 5.5 lists fault codes and names.

Table 5.5 List of fault code and name

Fault code	Fault description	Fault code	Fault description
1	Module overcurrent protection	2	ADC fault
3	Heatsink overheat	4	Brake unit fault
5	Fuse break fault	6	Output torque overload
7	Speed deviation	8	DC bus over-voltage protection
9	DC bus under-voltage	10	Output phase loss
11	Motor overcurrent at low speed	12	Encoder fault
13	Current detected while stop	14	Speed reversed direction in running
15	Speed detected while stop	16	Wrong motor phase
17	Overspeed in the same direction	18	Overspeed in the opposite direction
19	Wrong phase sequence of UVW encoder	20	Encoder communication fault
21	abc overcurrent	22	Brake detection trouble
23	Input overvoltage	24	UVW encoder disconnected
25	Spare	26	Encoder haven't self-learned
27	Output overcurrent	28	SIN/COS encoder fault
29	Input phase loss	30	Overspeed protection
31	Motor high speed overcurrent	32	Ground protection
33	Aging capacitor	34	External fault
35	Output unbalance	36	Wrong parameter setting
37	Current sensor fault	38	Braking resistor short circuit
39	Instantaneous current too large		

Chapter 6 Functional Parameters

This chapter introduces all elevator inverter function codes and information related as for reference.

6.1 Functional classification

Function codes are grouped by its function specification. Group of function code, see Table 6.1

Table 6.1 Group of function code

Function group	Name of group
P00	Password parameter and basic control mode
P01	Motor and encoder parameter, self-learning command
P02	PID regulator and starting/braking adjust parameter
P03	Speed reference parameter
P04	Torque reference and compensation parameter
P05	Digital input definition
P06	Digital output definition
P07	Analog input definition
P08	Analog output definition and display option of LCD, LED
P09	Other protection parameter

6.2 List of details of functions and their descriptions

6.2.1 Password and basic control mode

In function group code of P00 includes password login, setting, modification and parameter protection option. It also includes the selection for inverter basic control mode.

Function code	Name	Content	Setting range	Unit	Factory default	Remarks
P00.00	Password	It's login password. User can modify parameter only after signing in a correct password. (same as previous password set in P00.01)	0~65535	×	0	
P00.01	Modify or set password	Set parameter to set or modify inverter password. "0" means no password protected. It's a hidden parameter and doesn't display after setting.	0~65535	×	0	
P00.02	Basic control mode	Set inverter basic mode: 0: Voltage vector V/F control mode 1: Vector control without speed sensor 2: Torque control with speed sensor 3: Vector control with speed sensor	0/1/2/3	×	3	
P00.03	Input command mode	Input command setting: 0: Panel 1: Terminal	0/1	×	1	
P00.04	Language	Setting operator language: 0: Chinese 1: English	0/1	×	0	Can't be reset
P00.05	Version	Inverter version number			104.02	
P00.06	Two wire operation mode	0: Two wire 1, 1: Two wire 2 2: Three wire 1, 3: Three wire 2			0	
P00.07	Inertia stop mode	0: Inertia stop 1: Deceleration stop 2: decelerate + DC brake 3: Decelerate + keep excitation	0/1/2/3		0	

Function code	Name	Content	Setting range	Unit	Factory default	Remarks
P00.08	Keeping frequency at stopping		0~300	Hz	0.00	
P00.09	Time for keeping frequency at stopping		0~99.9	S	0.0	
P00.10	Time for keeping excitation at stopping		0~99.9	S	0.0	

Note 1: Password login

1) Before modifying or setting parameter, login password must be verified through P00.00. Password must be matched to the previous setting in P00.01. If so the inverter parameters can be set and modified, or if the logon failure, the parameters can't be set or modified.

2) By factory default, P00.01 is set to "0", so inverter is not password protected. At the first time login doesn't need password.

Note 2: Password modify and setting

1) When inverter leaves factory, P00.01 is set to "0", that means no password protection. If the password protection is needed, a password must be set by parameter setting in P00.01

2) P00.01 is a hidden parameter. It can't be reviewed once it was set. So the password must be remembered, or next login will fail and can't set or modify parameter.

3) P00.01 password can be modified. Password can be modified after successful login.

4) Set P00.01 password to "0" and password is removed.

Note 3: Basic control mode

P00.02 is the parameter for inverter basic control mode. As a specific inverter for elevator, it is regularly required to use vector control mode with speed sensor. Therefore the default parameter value "3" is taken in normal operation. During debugging, elevator may need to be in a maintenance slow mode if encoder is not installed yet. Set P00.02 temporarily to "0", and inverter control mode sets to voltage vector V/F. Please be reminded to set P00.02 back to "3" and the encoder wiring is done before elevator runs at high speed. Make sure the inverter runs on the vector mode with speed sensor.

6.2.2 Motor and encoder parameters, self learning commands

Parameter group P01 includes parameters for motor, encode, motor self-learning.

Function code	Name	Content	Setting range	Unit	Factory default	Remarks
P01.00	Motor type	0: Asynchronous; 1: Synchronous	0/1	×	0	
P01.01	Motor rated power	Set rated power for traction motor	0.40~160.00	KW	as per inverter specification	As per motor nameplate
P01.02	Motor rated current	Set rated current for traction motor	0.0~300.0	A	As per inverter specification	As per motor nameplate
P01.03	Motor rated frequency	Set rated frequency for traction motor	0.00~120.00	Hz	50.00	As per motor nameplate
P01.04	Motor rated rpm	Set rated rpm for traction motor	0~3000	rpm	1460	As per motor nameplate
P01.05	Motor rated voltage	Set rated voltage for traction motor	0~460	V	As per inverter specification	As per motor nameplate
P01.06	Motor poles	Set poles of traction motor	2~128	×	4	As per motor nameplate
P01.07	Motor rated slip frequency	Set rated slip frequency for traction motor	0~10.00	Hz	1.40	Refer to formula in 6-5
P01.08	Motor phase sequence	Set phase sequence of input voltage of traction motor, to modify the direction of motor running 1: Clockwise 0: Counterclockwise	0 / 1	×	1	
P01.09	Motor no-load rated current coefficient	Set proportion value of no-load current in rated current of traction motor	0.00~60.00	%	32.00	No required normally
P01.10	Motor stator resistance	Resistance of traction motor stator	0.000~65.000	Ω	As per inverter power	Only for asynchronous motor
P01.11	Motor rotor resistance	Resistance of traction motor rotor	0.000~65.000	Ω	As per inverter power	Only for asynchronous motor

Function code	Name	Content	Setting range	Unit	Factory default	Remarks
P01.12	Motor stator inductance	Inductance of traction motor stator	0.0000~ 6.0000	H	As per inverter power	Only for asynchronous motor
P01.13	Motor rotor inductance	Inductance value of traction motor rotor	0.0000~ 6.0000	H	As per inverter power	Only for asynchronous motor
P01.14	Motor mutual inductance	Mutual inductance value of traction motor	0.0000~ 6.0000	H	As per inverter power	Only for asynchronous motor
P01.15	Encoder type	Set encoder type used for motor speed detect 0: Incremental encoder 1: SIN/COS encoder 2: Endat encoder	0/1/2	×	0	
P01.16	Encoder pulse number	Number of pulses for an encoder cycle	500~16000	PPr	1024	
P01.17	Encoder phase angle	Value of encoder phase angle	0.0~360.0	Degree	0.0	The value obtains automatically by first running of inverter. Only for synchronous motor
P01.18	Encoder filtering time	Filtering time constant while setting encoder feedback speed input	1~30	ms	0	
P01.19	Encoder feedback direction	Set encoder feedback speed direction 1: Positive sequence 0: Negative sequence	0/1	×	1	
P01.20	Inverter input voltage	Set inverter input voltage	0~460	V	380	Can't initialize after setting

Note 1: Motor poles

P01.06 is for setting motor pole based on the nameplate.

If nameplate doesn't show the number of motor pole, it can be calculated according this formula:

$$\text{Motor poles} = (120 \times f) \div n$$

Where n is rated rpm, f is rated frequency.

Motor poles is rounded integrate even number from the calculation.

Note 2: Setting slip frequency

If nameplate doesn't show the number of slip frequency, the value of P01.07 can be calculated from this formula:

Set: rated frequency f (P01.03), rated rpm n (P01.04), motor poles p (P01.06)

Then: slip frequency = $f - ((n \times p) \div 120)$

For example: rated frequency f is 50Hz, rated rpm n is 1430 rpm, motor poles is 4

Then the value of P01.07 = $50 - ((1430 \times 4) \div 120) = 2.33\text{Hz}$

Note 3: Motor phase sequence

Normally P01.08 is set to "1". But if the running direction of motor reverses to the required direction, modifying parameter of P01.08 from "1" to "0" and reversing the direction.

Note 4: Motor internal parameter and self-learning

P01.10、P01.11、P01.12、P01.13 and P01.14 are only valid for asynchronous motor. They are motor internal parameters and can be obtained automatically by inverter self-learning to motor. For asynchronous motor, if motor parameters are set precisely, motor self-learning can be omitted. If precise motor parameters can't get on-site, or to ensure that inverter can control motor torque more accurately, inverter should be operated a self-learning operation at first time once elevator installed. Inverter then can retrieve accurate motor parameters like internal resistance, inductance. The procedure is as follow:

- 1) All wiring related to inverter, encoder must be correct and complete
- 2) Inverter power on, set all parameters required in group of P01
- 3) Try to operate the contactor to suck between inverter and motor (if there are two contactors, both of them must be operated) to connect the inverter and the motor well. And make sure that brake of traction machine is off.
- 4) In operator main screen, select "2 Motor tuning", then press "ENTER" key into self-learning screen;
- 5) "ATun=0" is displayed in self-learning screen, number on the right side of equal sign can be modified. Change "0" to "6" to an advance motor static learning mode, press "ENTER" again and motor self-learning starts.

Screen shows a consecutive number from 9, 8, 7, 6, 5, 4, 3, 2, 1 to 0. Self-learning finishes when 0 displayed. If error shows, please check and retry.

Note 5: Encoder phase angle

Parameter of P01.17 is for encoder phase angle. It is only for synchronous motor. It is not a pre-set parameter. It is obtained automatically from motor and encoder by first inverter operation.

Not 6: Encoder feedback direction

P01.19 can select the encoder feedback direction. Default value is "1". Normally it doesn't need to be changed. When encoder is not correctly connected and it causes reversed feedback direction, parameter P01.19 can be modified and correct the direction.

6.2.3 PID regulator and start/brake adjusting parameters

Parameter group P02 includes PID regulator, starting/stopping adjustment parameters.

Parameter for tuning PWM carrier frequency is also included.

Function code	Name	Content	Setting range	Unit	Factory default	Remarks
P02.00	Zero servo gain P0	PID regulator gain value under zero servo	0.00~ 655.35	×	130.00	Recommend adjusting range: Min – Half of default value; Max – Twice as default value
P02.01	Zero servo integral I0	PID regulator integral value under zero servo			80.00	Recommend adjusting range: Min – Half of default value; Max – Twice as default value
P02.02	Zero servo differential D0	PID regulator differential value under zero servo			0.50	Recommend adjusting range: Min – Half of default value; Max – twice as default value
P02.03	Low speed gain P1	PID regulator gain value effected only when speed reference lower than switch frequency F0			70.00	Recommend adjusting range: Min – Half of default value; Max – Twice as default value
P02.04	Low speed integral I1	PID regulator integral value effected only when speed reference lower than switch frequency F0			30.00	Recommend adjusting range: Min – Half of default value; Max – Twice as default value
P02.05	Low speed differential D1	PID regulator differential value effected only when speed reference lower than switch frequency F0			0.50	Recommend adjusting range: Min – Half of default value; Max – Twice as default value
P02.06	Middle speed gain P2	PID regulator gain value effected when speed reference between switch frequency F0 and F1			120.00	
P02.07	Middle speed integral I2	PID regulator integral value effected when speed reference between switch frequency F0 and F1			25.00	
P02.08	Middle speed differential D2	PID regulator differential value effected when speed reference between switch frequency F0 and F1			0.20	
P02.09	High speed gain P3	PID regulator gain value effected only when speed reference higher than switch frequency F1	140.00	Recommend adjusting range: Min – Half of default value; Max – Twice as default value		

Function code	Name	Content	Setting range	Unit	Factory default	Remarks
P02.10	High speed integral I3	PID regulator integral value effected only when speed reference higher than switch frequency F1			5.00	Recommend adjusting range: Min – Half of default value; Max – Twice as default value
P02.11	High speed differential D3	PID regulator differential value effected only when speed reference higher than switch frequency F1			0.10	Recommend adjusting range: min – half of default value; max – twice as default value
P02.12	Low speed switch frequency F0	Set switch frequency parameter of PID regulator for low speed point, it is based on the percentage number of rated frequency. If rated frequency is 50Hz, the needed switch frequency F0 is 10Hz, 20 should be set, because 10Hz is 20% of 50Hz.	0.~ 100.0	%	1.0	
P02.13	High speed switch frequency F1	Set switch frequency parameter of PID regulator for high speed point, it is based on the percentage number of rated frequency. If rated frequency is 50Hz, the needed switch frequency F0 is 40Hz, 80 should be set, because 40Hz is 80% of 50Hz	0.0~ 100.0	%	50.0	
P02.14	Excitation time	When inverter receives operation command, operation signal sends out after this time of excitation. Brake is released	0.0~ 10.0	s	0.3	No applicable for controlling synchronous motor
P02.15	Zero servo time	The time for keeping torque from inverter sends out operation signal to accelerate elevator	0.0~ 30.0	s	0.5	
P02.16	Brake release time	Mechanical action time for braking	0.00~ 30.00	s	0.25	
P02.17	PWM carrier frequency	Set value of PWM carrier frequency	1.100~ 11.000	kHz	6.000	Normally unchanged
P02.18	PWM carrier width	Set changing value of PWM carrier width	0.000~ 1.000	kHz	0.000	Normally unchanged
P02.19	Current slow descent down time	Time from remove inverter operation command to inverter zero current output	0.00~ 10.00	s	0.00	

Function code	Name	Content	Setting range	Unit	Factory default	Remarks
P02.20	Regulator mode	0: Fast mode 1: Standard mode 2: Moderate mode 3: Slow mode	0/1/2/3	×	1	

Note 1: Starting adjustment

New technology of starting compensation with no-load sensor is developed in this inverter. Elevator obtains excellent starting comfort without installing weigh device. The main parameters for starting adjustment include P02.00, P02.01, P02.02, P02.14, P02.15 and P02.16.

P02.00, P02.01 and P02.02 are proportion, integral and differential of speed loop PID adjustment while starting. They effect continuously in zero servo time (parameter setting P02.15). P02.00 is the P value of PID (proportion parameter). P02.01 is the I value of PID (integral parameter). P02.02 is the D value of PID (differential parameter).

P02.14 is a parameter for excitation time. After inverter receives operation direction (or enable) signal from controller, it will send operation response signal back to controller after this excitation time. Only now can the controller release the brake. To extend proper excitation time can help torque export while starting, but too long excitation time will cause slow starting and affects the operation efficiency. The parameter is only applicable for controlling of asynchronous motor.

P02.15 is a parameter for zero servo time. Zero servo is a time between inverter excitation end and providing speed reference, and outputting a keep torque at zero export speed. This parameter also determines action time of three servo parameters PID, P02.00, P02.01 and P02.02. Action time for zero servo shows in diagram Fig. 6.1

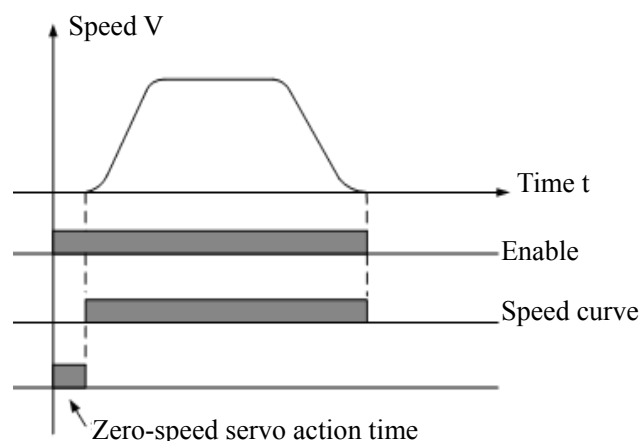

Fig. 6.1 Zero servo action time

P02.16 is a parameter for the brake release time. The time needs to be set according the actual mechanical action time.

The function of proportional constant P in PID regulator is: to increase P value can improve the system capability of response and following, but too big a P value will cause overshoot and oscillation. Fig. 6.2 shows the feedback tracking effected from P. Integral constant I affects system response time, the bigger the I value, the faster the response time is. To increase I value if system

overshoot is too big or dynamic response time is too slow. But too big I value will cause system oscillation. Fig. 6.3 shows the feedback tracking effected from I. Differential constant D affects the sensitivity of system response. To increase D can made system response more sensitive, but too big D value can cause system oscillation as well.

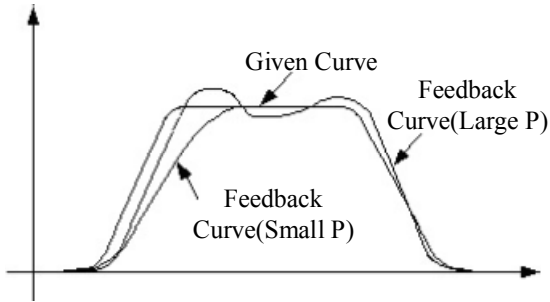

Fig. 6.2 Feedback tracking effect from proportional constant P

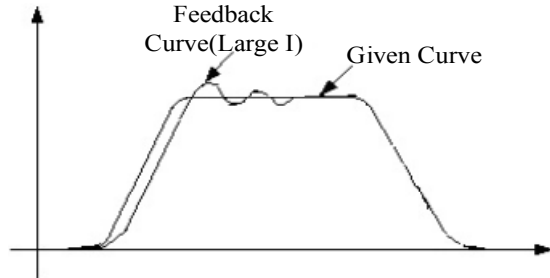

Fig. 6.3 Feedback tracking effect from proportional constant I

Proportional constant P is usually adjusted first during the PID constant adjustment. To increase P value as big as possible while keeping the system has no oscillation. Then regulating integral constant I and make system response quickly while keeping overshoot at a low level. If the adjustment of P and I still can't improve the system sensitivity, differential constant D can be tuned up appropriately.

Note 2: Operation comfort adjustment

Function codes P02.03 ~ P02.13 are PID regulator parameters for adjustment of individual sections during operation (refer to Fig. 6.4). To adjust parameters P02.03 ~ P02.13 can improve the comfort in different sections during elevator running.

P02.03, P02.04, P02.05 are low speed section (see Fig. 6.4) PID parameters P1, I1, D1. All function these parameters have been introduced in note 1. P02.06, P02.07, P02.08 are moderate speed section (see Fig. 6.4) PID parameters P2, I2, D2. And P02.09, P02.10, P02.11 are high speed section (see Fig. 6.4) PID parameters P3, I3, D3. P02.12 and P02.13 are two switch frequencies (or thresholds) used for dividing low speed, moderate speed, and high speed sections in operating curve. Speed lower than P02.12 (f1) is defined as low speed section, speed higher than P02.13 (f2) is defined as high speed section, speed between f1 and f2 is defined as the moderate speed section.

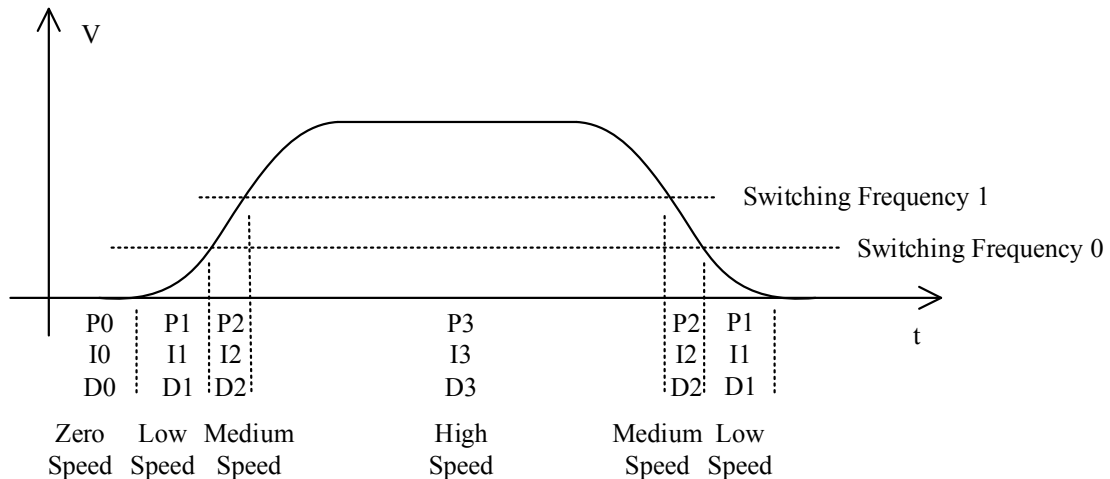

Fig 6.4 The running curve sections of the PI controlling

Note 3: Carrier frequency and carrier width

P02.17 is a parameter for inverter PWM carrier frequency. The higher the carrier frequency, the lower the motor noise has. But it will increase loss. User usually don't need to set it, a default value (6KHz) can be taken. If it is necessary to reduce the motor noise by increasing carrier frequency at installing site, due to the factor of increasing inverter loss, inverter needs to reduce 5% for every 1KHz increment when carrier frequency surpasses default value. P02.18 is a parameter for carrier width. Usually user can use its default value and don't need to adjust it. Its function is to allow carrier frequency changed automatically within the set range. It can also reduce motor noise in certain circumstance. For example, P02.17 is set to 6KHz, P02.18 is set to 0.4KHz, the actually inverter carrier frequency will be varied between 5.8~6.2 KHz automatically.

Note 4: Current ramp down time

P02.19 is a parameter of the current ramp down time from inverter receiving stop output command to zero actual output current. A default value 0 is used normally. In some special circumstance, the rush releasing of inverter current at elevator stopping causes loud motor noise. This parameter can be increased appropriately. But the value should not be too big, it should not greater than the delay time for main contactor release, otherwise it will cause contactor releasing with electric and contact arc discharge. It will affect the lifespan of contactor. And the loop is broken after contactor releasing, inverter can't output current anymore.

Note 5: Regulator mode parameter

P02.20 is a PID regulator mode parameter. The default value is 1: standard mode.

6.2.4 Speed reference parameters

In parameter group P03, all speed reference related parameters are set.

Function code	Name	Content	Setting range	Unit	Factory default	Remarks
P03.00	Type of speed reference	0: Panel setting 1: Digital controlled multi-section speed reference 4: AI0 analog speed reference 6: AI1 analog speed reference	0/1/4/6	×	4	Invalid when P00.02 is set to 2
P03.01	Acceleration time	The parameter determines accelerate slope of elevator (the constant acceleration). It is an acceleration time for elevator from zero speed to maximum speed under constant acceleration. Please note, it is not a mean acceleration. Mean acceleration relates also two accelerate rounds size beside this value.	0.10~ 60.00	s	2.50	Only used in multi-section speed reference
P03.02	Deceleration time 1	The parameter determines decelerate slope of elevator (the constant deceleration). It is a deceleration time for elevator from maximum speed to zero speed under constant deceleration. Please note, it is not a mean deceleration. Mean deceleration relates also two decelerate rounds size beside this value.	0.10~ 60.00	s	2.50	Only used in multi-section speed reference
P03.03	Time for acceleration round 0	Set time for acceleration round at starting section in S curve. The longer the time is, the bigger the round is.	0.00~ 10.00	s	1.30	Only used in multi-section speed reference
P03.04	Time for acceleration round 1	Set time for acceleration round at constant speed section in S curve. The longer the time, the bigger the round is.	0.00~ 10.00	s	1.30	Only used in multi-section speed reference

Function code	Name	Content	Setting range	Unit	Factory default	Remarks
P03.05	Time for deceleration round 0	Set time for deceleration round at decelerating section in S curve. The longer the time, the bigger the round is.	0.00~ 10.00	s	1.30	Only used in multi-section speed reference
P03.06	Time for deceleration round 1	Set time for deceleration round at decelerating end section in S curve. The longer the time, the bigger the round is.	0.00~ 10.00	s	1.30	Only used in multi-section speed reference
P03.07	Speed reference 1	Set speed reference 1 at digital multi-section speed reference in unit of Hz.	0.00~ 60.00	Hz	2.50	Only used in multi-section speed reference
P03.08	Speed reference 2	Set speed reference 2 at digital multi-section speed reference in unit of Hz.	0.00~ 60.00	Hz	1.20	Only used in multi-section speed reference
P03.09	Speed reference 3	Set speed reference 3 at digital multi-section speed reference in unit of Hz.	0.00~ 60.00	Hz	1.50	Only used in multi-section speed reference
P03.10	Speed reference 4	Set speed reference 4 at digital multi-section speed reference in unit of Hz.	0.00~ 60.00	Hz	5.00	Only used in multi-section speed reference
P03.11	Speed reference 5	Set speed reference 5 at digital multi-section speed reference in unit of Hz.	0.00~ 60.00	Hz	25.00	Only used in multi-section speed reference
P03.12	Speed reference 6	Set speed reference 6 at digital multi-section speed reference in unit of Hz.	0.00~ 60.00	Hz	40.00	Only used in multi-section speed reference
P03.13	Speed reference 7	Set speed reference 7 at digital multi-section speed reference in unit of Hz.	0.00~ 60.00	Hz	50.00	Only used in multi-section speed reference
P03.14	Speed reference 8	Set speed reference 8 at digital multi-section speed reference in unit of Hz.	0.00~ 60.00	Hz	0.00	Only used in multi-section speed reference
P03.15	Speed reference 9	Set speed reference 9 at digital multi-section speed reference in unit of Hz.	0.0~60.0	Hz	0.0	Only used in multi-section speed reference
P03.16	Speed reference 10	Set speed reference 10 at digital multi-section speed reference in unit of Hz.	0.0~60.0	Hz	0.0	Only used in multi-section speed reference
P03.17	Speed reference 11	Set speed reference 11 at digital multi-section speed reference in unit of Hz.	0.0~60.0	Hz	0.0	Only used in multi-section speed reference

Function code	Name	Content	Setting range	Unit	Factory default	Remarks
P03.18	Speed reference 12	Set speed reference 12 at digital multi-section speed reference in unit of Hz.	0.0~60.0	Hz	0.0	Only used in multi-section speed reference
P03.19	Speed reference 13	Set speed reference 13 at digital multi-section speed reference in unit of Hz.	0.0~60.0	Hz	0.0	Only used in multi-section speed reference
P03.20	Speed reference 14	Set speed reference 14 at digital multi-section speed reference in unit of Hz.	0.0~60.0	Hz	0.0	Only used in multi-section speed reference
P03.21	Speed reference 15	Set speed reference 15 at digital multi-section speed reference in unit of Hz.	0.0~60.0	Hz	0.0	Only used in multi-section speed reference
P03.22	Creep speed selection	Parameter for creep speed section	0 or 3.07~3.21		0.00	Only used in multi-section speed reference
P03.23	Stop section speed	Parameter for stop speed section	0 or 3.07~3.21		0.00	Only used in multi-section speed reference
P03.24	Deceleration time 2	Speed reducing time from crawling to stopping	0~360.00	s	5.00	
P03.25	Select acceleration round 1	Before end of acceleration, and target speed is slower than current speed, set this parameter to determine the execution of acceleration round 1.	0~5		0	0: Normal round 1: 1/2 of normal round 2: 1/4 of normal round 3: 1/8 of normal round 4: 1/16 of normal round 5: No round

Note 1: Selection of speed reference mode

Parameter group P03.00 can select speed reference mode. The most common modes are 4 (AI0 analog speed reference) and 1 (digital controlled multi-section speed reference). Parameters P03.01 ~ P03.21 are only valid when P03.00 is set to 1.

Note 2: Analog speed reference

The graph shows the relation between analog signal and speed reference in analog speed reference, see Fig. 6.5.

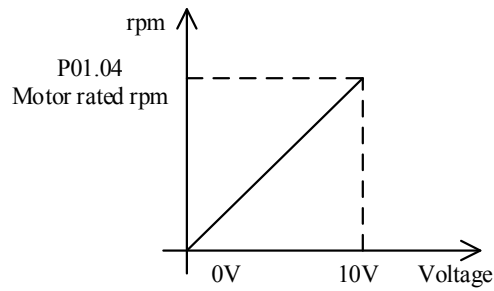

Fig. 6.5 Relation between rpm and analog signal

Note 3: Multi-section speed curve, see Fig. 6.6.

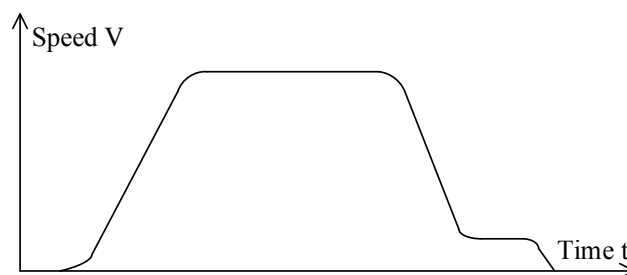

Fig. 6.6 Multi-section speed curve

Note 4: Tuning parameters of multi-section speed curve

P03.01 ~ P03.06 are parameters for tuning elevator operation curve S (speed curve) at digit multi-section speed reference. They are set for acceleration time (P03.01), deceleration time (P03.02), acceleration round time (P03.03 and P03.04), deceleration round time (P03.05 and P03.06). These parameters affect the characteristics of S curve, therefore directly relate to elevator operation efficiency and comfort. The specific positions of those parameters in elevator operation curve S can be seen in Fig. 6.7.

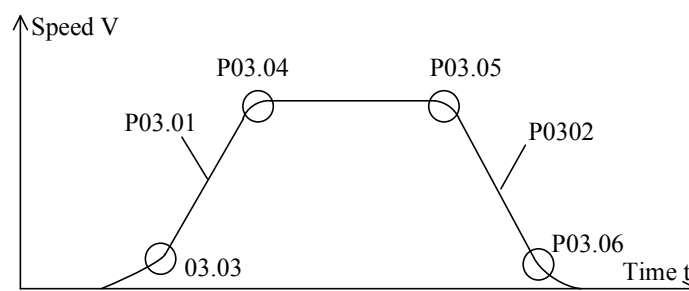

Fig. 6.7 Parameter position in elevator operation curve S

Important:

- 1) Acceleration time P03.01 and deceleration time P03.02 of curve S can be tuned in their range.

To tune value small, acceleration (deceleration) speed will be increased. It will improve the efficiency, but reduce the comfort. So it should be considered to make a proper balance.

2) In acceleration section, acceleration round time P03.02 at beginning and P03.04 at ending can be tuned respectively at their range. To tune value small means to increase the value of acceleration. It improves operation efficiency, but may reduce the comfort at two round positions during accelerating time. So it should be considered to make a proper balance.

3) In deceleration section, deceleration round time P03.05 at beginning and P03.06 at ending can be tuned respectively at their range. To tune value small means to increase the value of deceleration. It improves operation efficiency, but may reduce the comfort at two round positions during decelerating time. It should be considered to make a proper balance.

Note 5: Fig. 6.8 shows the affection of S curve parameters to elevator operation curve

The slope of speed curve (S curve) is decided by P03.01 and P03.02. The smaller the value, the steeper the curve is. Four speed curve related rounds are decided by P03.03 ~ P03.06. The smaller the value, the smaller the round is. (the bigger the curvature is)

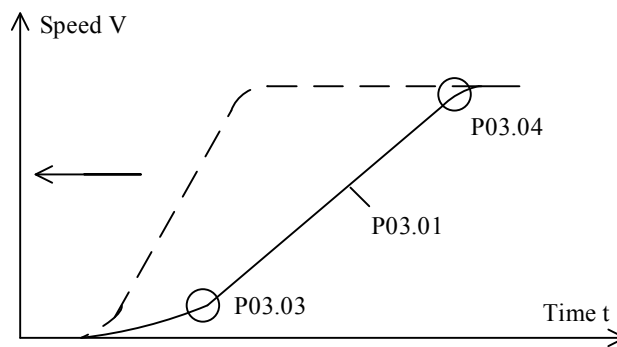

Fig. 6.8 Affection for S curve to elevator operation curve

Note 6: P03.07 ~ P03.21 define the fifteen speed section parameters from speed reference 1 to speed reference 15. Sixteen combinations are formed based on four input binary codes at digit multi-section speed reference 0~3. The sixteen states correspond to 15 speed references from P03.07 to P03.21, and speed reference “0” (combination code 0). The relationship between multi-section speed port signal and speed reference command is shown in the following table 6.2

Table 6.2 Multi-section speed input signal vs. speed reference

Multi-section speed combination code	Multi-section speed reference 3	Multi-section speed reference 2	Multi-section speed reference 1	Multi-section speed reference 0	Speed reference
0	0	0	0	0	Speed reference 0
1	0	0	0	1	Speed reference 1 (P03.07)
2	0	0	1	0	Speed reference 2 (P03.08)
3	0	0	1	1	Speed reference 3 (P03.09)
4	0	1	0	0	Speed reference 4 (P03.10)
5	0	1	0	1	Speed reference 5 (P03.11)
6	0	1	1	0	Speed reference 6 (P03.12)
7	0	1	1	1	Speed reference (P03.13)
8	1	0	0	0	Speed reference 8 (P03.14)
9	1	0	0	1	Speed reference 9 (P03.15)
10	1	0	1	0	Speed reference 10 (P03.16)
11	1	0	1	1	Speed reference 11 (P03.17)
12	1	1	0	0	Speed reference 12 (P03.18)
13	1	1	0	1	Speed reference 13 (P03.19)
14	1	1	1	0	Speed reference 14 (P03.20)
15	1	1	1	1	Speed reference 15 (P03.21)

In above table, state 0 means no input signal at that port, state 1 means having input signal. For example: if speed reference 0 and speed reference 1 have input signal, speed reference 2 and speed reference 3 haven't input signal, the binary combination of this code is "0011" = 3. Speed reference 3 is matched and the value of speed reference is decided by parameter of P03.09 in this case. In normal elevator operation (elevator velocity less than 2.5 m/s), using only seven speed references is enough. Therefore only three (0, 1, 2, without 3 input port) of these four speed reference input ports need to be used. Parameters P03.14 ~ P03.21 are usually unused.

6.2.5 Torque reference, torque compensation parameters

Parameter group P04 defines the parameters for torque reference and torque compensation are set.

Function code	Name	Content	Setting range	Unit	Factory default	Remarks
P04.00	Torque reference mode	0: Panel setting 1: AI0 analog torque reference 2: AI1 analog torque reference	0/1/2	×	0	When torque reference mode is not used in most case, this value is set to 0. If this mode is used, speed reference mode needs to be off. (P03.00 set to 0) It is valid only when the value of P00.02 is 2
P04.01	Torque compensation reference mode	0: No torque compensation 1: Compensation based on light/heavy load switch 2: AI0 analog torque reference 3: AI1 analog torque reference	0/1/2/3	×	0	
P04.02	Direction of torque compensation	0: Positive direction 1: Opposite direction	0/1	×	0	
P04.03	Torque compensation gain	Set torque compensation gain	0.0~ 200.0	%	100.0	Only valid when P04.01 is set to 2~3
P04.04	Torque compensation offset	Set torque compensation offset	0.0~ 100.0	%	0.0	Only valid when P04.01 is set to 2~3
P04.05	Light load switch compensation	Set compensation of downward torque when light load switch triggered	0.0~ 100.0	%	0.0	Only valid when P04.01 is set to 1
P04.06	Heavy load switch compensation	Set compensation of upward torque when heavy load switch triggered	0.0~ 100.0	%	0.0	Only valid when P04.01 is set to 1
P04.07	Output torque limit	Set output torque limit, it is a percentage value of rated torque	0~200	%	175	
P04.08	ARD operation speed	Operation speed in ARD mode	0~655.3 5	Hz	0	Only valid in ARD operation mode. The parameter is unfunctional if the value is 0
P04.09	ARD torque limit	Set torque limit in ARD operation mode	0~200	%	150	Only valid in ARD operation mode
P04.10	Sliding coefficient	Set the sliding parameter	0/6606~ 6616		0	It can run for 10 times without the current limitation by set to 6616. It exists lots of risk

Note 1: Torque reference mode

Torque reference mode is not selected normally in elevator control system. A factory default

value 0 is taken in most cases. In case the system needs to take torque reference mode, P04.00 is recommended to set to 1. Turning analog input AI0 as torque reference input, speed reference is no more required and P03.00 needs to be set to 0.

Note 2: Torque compensation

AS320 series elevator inverter has function of no weighing and preload compensation at starting. For synchronous gearless elevator, if SIN/COS encoder is taken, it can reach the perfect starting comfort even without adding preload torque compensation. For asynchronous geared drive, it also can reach the ideal starting result without adding preload torque compensation. If the ABZ incremental encoder is used into the synchronous gearless elevator, increasing an appropriate preload torque compensation at starting can improve the elevator comfort at start.

P04.01 is a parameter for selecting the mode of preload torque compensation. This torque compensation function is not used when P04.01 is set to 0. To select light or heavy load switch compensation plan, P04.01 needs to be set to 1. System takes more accurate analog input compensation plan when P04.01 is set to 2 or 3. If P04.01 is set as 2, AI0 analog port is taken as compensation input port. If P04.01 is set as 3, then AI1 analog port is taken as compensation input port. Usually AI0 is used for the input of speed reference. If the torque compensation for analog input is used, it is recommended to set the P04.01 value to 3, and select AI1 analog port as torque compensation input port.

P04.03, P04.04 are parameters for tuning torque compensation when P04.01 is 2 or 3. P04.04 is compensation offset and don't need to tune normally. The default value is 0. P04.03 is compensation gain. Tuning up the value will increase compensation under the condition of same analog port compensation input. Reversed tuning will reduce the compensation. If feeling downward impact at heavy load starting (slip back when going upward, too rush when going downward), upward impact at light load starting (slip back when going downward, too rush when going upward), that means it is short of compensation. Compensation gain P04.03 needs to be increased in this case. On the contrary, if feeling upward impact at heavy load starting (slip back when going downward, too rush when going upward), downward impact at light load starting (slip back when going upward, too rush when going downward), that the compensation is too big. Compensation gain P04.03 needs to be reduced in this case.

P04.05, P04.06 are two simple torque compensation parameters for light and heavy load switches. No precise weighing device is needed while taking this simple torque compensation method. Only two simply weighing switches, light load switch and heavy load switch, are required. Usually light load switch can be tuned when the car load is less than 25% of rated load capacity. Heavy load switch can be tuned when the car load is more than 75% of rated load capacity. Both switches are connected to the digit input of inverter. P04.05 is a parameter for simple light load torque compensation when light load switch is active. If feeling upward impact at light load starting (slip back when going downward by down collective, too rush when going upward), that means it is short of light load compensation. P04.05 needs to be tuned up. On the contrary, if feeling downward impact at light load starting (slip back when going upward, too rush when going downward), the light load compensation is too big. P04.05 needs to be tuned down. Same for heavy load switch, P04.06 is a parameter for simple heavy load torque compensation when heavy load switch is active. If feeling downward impact at heavy load starting (slip back when going upward, too rush when going downward), that means it is short of heavy load compensation. P04.06 needs to be tuned up.

On the contrary, if feeling upward impact at heavy load starting (slip back when going downward, too rush when going upward), the heavy load compensation is too big. P04.06 needs to be tuned down.

P04.02 is a parameter for torque compensation direction. The factory default value 0 is used in normal situation. If the system torque compensation direction is reversed by other reason, it can be simply corrected by changing the parameter value from 0 to 1. To determine whether the torque compensation direction is correct or not, you can: in light load (or light load switch is active), tuning up the value of P04.03 (or P04.05), upward impact reduces or downward impact increases at starting. The compensation direction is set correctly. On the contrary, if tuning up value causes reducing downward impact or increasing upward impact at starting, the compensation direction is wrong and needs to be corrected. Same in heavy load (or heavy load switch is active), tuning up the value of P04.03 (or P04.06), downward impact reduces or upward impact increases at starting. The compensation direction is set correctly. If tuning up value causes reducing upward impact or increasing downward impact at starting, the compensation direction is wrong and needs to be corrected.

AS320 series elevator inverter developed a creative design for the starting technology of permanent magnetic synchronous gearless elevator drive and has a unique advantage. It has excellent stable start performance without any torque compensation if the SIN/COS encoder is used. If ABZ incremental encoder with 8192 pulse is used, also perfect starting comfort can be reached by using simple torque compensation method with light/heavy load switches. Compare to SIN/COS encoder, ABZ incremental encoder has advantage in price, easy wiring and better anti-interference performance. To use simply torque compensation method with light/heavy load switch is a great advantage.

6.2.6 Binary input parameters

Parameter group P05 defines the function of digital input terminal and input related features.

Function code	Name	Content	Setting range	Unit	Factory default	Remarks
P05.00	Definition of X0 input terminal function	Digital input function code: 0: No function (The port is invalid) 3: Digital multi-section speed reference 0 4: Digital multi-section speed reference 1	0~20 103~ 120	×	0	Factory setting: P05.02=3: Terminal X2 inputs multi-section speed reference 0
P05.01	Definition of X1 input terminal function	5: Digital multi-section speed reference 2 6: Digital multi-section speed reference 3 7: Up going command 8: Down going command			0	P05.03=4: Terminal X3 inputs multi-section speed reference 1 P05.04=5: Terminal X4 inputs multi-section speed reference 2
P05.02	Definition of X2 input terminal function	13: External reset signal 14: External fault signal 15: External encoder phase angle adjusting command			3	P05.06=7: Terminal X6 inputs up going signal

Function code	Name	Content	Setting range	Unit	Factory default	Remarks
P05.03	Definition of X3 input terminal function	16: Operating in emergency power supply 17: Weighing compensation input (for special user only) 18: Base block signal			4	P05.07=8: Terminal X7 inputs down going signal P05.05=18: Terminal X5 inputs base block signal
P05.04	Definition of X4 input terminal function	19: Light load compensation switch 20: Heavy load compensation switch 21: Output contactor testing signal 22: Braking contactor testing signal			5	
P05.05	Definition of X5 input terminal function	23: Braking switch testing signal 34: Inching input signal 35: Hardware base block signal(coordinating the controlling of KMY and KMB sequential logic)			18	
P05.06	Definition of X6 input terminal function	Other: Reserved			7	
P05.07	Definition of X7 input terminal function				8	
P05.08	Number of digital input filtering		1~99	time s	5	
P05.09	Frequency of inching operation		0~655.3 5	Hz	0	
P05.10	Acceleration time 2 (inching acceleration time)		0.1~ 360.00	S	5.00	
P05.11	deceleration time 2 (inching deceleration time)		0.1~ 360.00	S	5.00	

Note 1: Function code description

- 1) When function code is 0, the related port has not any definition and isn't used.
- 2) If the function code is set as 3 (or 103), the related port is defined as digital multi-section

speed reference 0 input; if the function code is 4 (or 104), the related port is defined as digital multi-section speed reference 1 input; if the function code is 5 (or 105), the related port is defined as digital multi-section speed reference 2 input; if the function code is 6 (or 106), the related port is defined as digital multi-section speed reference 3 input; Do they work only when P03.00 is set to 1 (digital multi-section speed reference). Combined these inputs and given the multi-section speed reference command. Details refer to the explanation in Table 6.2.

3) When function code is 15 (or 115), the related port is defined as external encoder phase angle adjusting command. Because the inverter has automatic encoder phase angle adjusting function, this command is not required in normal situation. This function is only prepared for special user.

4) As to the function code 16 (or 116), the relates the port is defined as operation signal input in emergency power supply. This function code is used to define input ports for emergency power operation signal. The input port must be defined if there is an emergency operation function. Corresponding to that input signal at the input ports, the elevator operates in emergency power supply mode. The inverter allows to be operated in low speed by low bus cable voltage.

5) For the function code 7 (or 107), 8 (or 108), the corresponding port definition are upward going signal and the downward going signal. This function code defines the input port for elevator upward going signal and downward going signal. Upward going and downward going signals must be available in all kinds of speed reference mode (digital multi-section speed reference, analog voltage speed reference). Function code 7 (or 107), 8 (or 108) can only define one port respectively, can't define multi ports.

6) Function code 18 (or 118) relates the port for base block signal input. If there is base block signal at input terminal, inverter will cut off the power module output right away.

7) Function code 19 (or 119), 20 (or 120) match to the input of light load switch and heavy load switch. These two input ports must be defined if light load switch, heavy load switch simple torque compensation method (P04.01 is 1) is used by system.

Note 2: Definition for some special function inputs at their factory default setting

1) Input port for controlling inverter operation signal

P05.06 = 7, X6 is defined as input port for up going command signal

P05.07 = 8, X7 is defined as input port for down going command signal

P05.05 = 18, X5 is defined as input port for base block

2) Input port for multi-section speed reference command

P05.00 = 3, X0 is defined as input port for multi-section speed reference 0

P05.01 = 4, X1 is defined as input port for multi-section speed reference 1

P05.02 = 5, X2 is defined as input port for multi-section speed reference 2

In elevator control system, most elevator speed doesn't exceed 2.5 m/s. Three multi-section speed references input port (can be combined to 7 speed reference commands) are enough in this case. The default factory setting defines only three speed reference input ports. If elevator speed exceeds 3 m/s and using digital multi-section speed reference mode, function code 6 (or 106) must also be defined as multi-section speed reference 3 for input port.

Note 3: Input contact NO, NC setting

In order to use digital input port simply, all contacts of input ports can be set as NO or NC as user wishes. NO means the input signal is valid if it is connected among the input signal and XC

(common port). Invalid means no input signal. Otherwise when input port is defined as NC, the input signal is valid if it's disconnected among the input signal and XC (common port). Valid means no input signal. Function codes 1 ~20 are used to set the input port as NO contacts. Function codes 101 ~120 are used to set the input port as NC contacts. In function code, the same two last digits indicate the same function of the input port. For example, the definition for 106 and 6 (6 equals to 06, 0 is omitted) is same. They all stand for input port for multi-section speed reference 3. The only difference is that NC contact is set for 106, and NO for 6.

6.2.7 Binary output parameters

Parameter group P06 defines the function of digital output terminal and output related features.

Function code	Name	Content	Setting range	Unit	Factory default	Remarks
P06.00	Output function definition K1 Port (Relay)	Set digital output terminal function: 0: No definition;	0~15 101~115	×	0	Relay matching K1 has three output terminals, 1A, 1B and 1C. Contact between 1A and 1B is NO. 1B and 1C is NC
P06.01	Output function definition K2 Port (Relay)	1: Inverter operation preparation completion; 2: Inverter fault; 3: Inverter running signal(RUN); 4: Frequency reached			0	Relay matching K2 has three output terminals, 2A, 2B and 2C. Contact between 2A and 2B is NO. 2B and 2C is NC
P06.02	Output function definition Y0 Port	signal(FAR); 5: Frequency speed consistent(FDT);			3	Terminal Y0 is inverter operation signal
P06.03	Output function definition Y1 Port	6: Inverter running at 0 speed; 7: DC bus voltage is not less than 85% of the rated voltage;			2	Terminal Y1 is inverter fault signal
P06.04	Output function definition Y2 Port	8: Greater than 5% the rated current during operation, greater than 10% of the rated current at stop;			0	
P06.05	Output function definition Y3 Port	9: Being self-adjusting 10: Speed detection 1; 11: Speed detection 2; 12: When fault forecasted, output 1;when normal, output 0; 13: Self-adjusting request (synchronous motor); 14: Zero servo torque direction output; 15: Zero current detected; 16: Distinguish the state of power			0	

		generation or motor; 17: Output contactor control; 18: Brake control; 21: Radiator heat output; 23: Deceleration output; 19, 20, 22, 24 and so on are reserved.				
P06.06	K1 terminal output delay	Set delay action time of output terminal K1 after actual ON signal	0.0~ 60.0	s	0	
P06.07	K1 terminal reset delay	Set delay reset time of output terminal K1 after actual OFF signal	0.0~ 60.0	s	0	
P06.08	K2 terminal output delay	Set delay action time of output terminal K2 after actual ON signal	0.0~ 60.0	s	0	
P06.09	K2 terminal reset delay	Set delay reset time of output terminal K2 after actual OFF signal	0.0~ 60.0	s	0	
P06.10	Y0 terminal output delay	Set delay action time of output terminal Y0 after actual ON signal	0.0~ 60.0	s	0	
P06.11	Y0 terminal reset delay	Set delay reset time of output terminal Y0 after actual OFF signal	0.0~ 60.0	s	0	
P06.12	Y1 terminal output delay	Set delay action time of output terminal Y1 after actual ON signal	0.0~ 60.0	s	0	
P06.13	Y1 terminal reset delay	Set delay reset time of output terminal Y1 after actual OFF signal	0.0~ 60.0	s	0	
P06.14	Y2 terminal output delay	Set delay action time of output terminal Y2 after actual ON signal	0.0~ 60.0	s	0	
P06.15	Y2 terminal reset delay	Set delay reset time of output terminal Y2 after actual OFF signal	0.0~ 60.0	s	0	
P06.16	Y3 terminal output delay	Set delay action time of output terminal Y3 after actual ON signal	0.0~ 60.0	s	0	
P06.17	Y3 terminal reset delay	Set delay reset time of output terminal Y3 after actual OFF signal	0.0~ 60.0	s	0	

P06.18	Non zero current detect threshold at stopping	When stopping, inverter has current and it is greater than this set value, non zero current detection signal is valid. It is a percentage data. The actual value is this data multiply by the rated current and divided by 100	0.0~ 100.0	%	2.0	
P06.19	Any frequency speed detection	A frequency detection reference data, used with P06.20	0.00~ 60.00	Hz	1.00	Details see following note 7
P06.20	Any frequency detection width	A frequency detection width and used with P06.19	0.00~ 20.00	Hz	0.20	Details see following note 7

Note 1: Six parameters setting: P06.00 ~ P06.05, output ports definition: K1 ~K2 and Y0 ~ Y3. Their data range and function description of the output port corresponding to each data set are as follows:

0: no function

1 or 101: inverter complete the peroration to operate (RDY)

1: inverter passes self-checking and fault-free, related output port is connected, otherwise disconnected.

101: inverter passes self-checking and fault-free, related output port is disconnected, otherwise connected.

2 or 102: inverter fault

2: inverter has fault and stops, related output port is connected, otherwise disconnected.

102: inverter has fault and stops, related output port is disconnected, otherwise connected.

3 or 103: inverter run signal (RUN)

3: inverter responses run command and be able to run normally, related output port is connected, otherwise disconnected.

103: inverter responses run command and be able to run normally, related output port is disconnected, otherwise connected.

6 or 106: inverter runs at zero speed

6: inverter outputs 0 frequency in operation, related output port is connected, otherwise disconnected.

106: inverter outputs 0 frequency in operation, related output port is disconnected, otherwise connected.

7 or 107: DC bus voltage is not less than 85% of rated voltage

7: When DC bus voltage is not less than 85% of rated voltage, related output port is connected, otherwise disconnected.

107: When DC bus voltage is not less than 85% of rated voltage, related output port is

disconnected, otherwise connected.

8 or 108: surpassing 5% over rated current in running, 10% over rated current in stopping

8: meeting above conditions, related output port is connected, otherwise disconnected.

108: meeting above conditions, related output port is disconnected, otherwise connected.

9 or 109: during self-learning

9: during self-learning, related output port is connected, otherwise disconnected.

109: during self-learning, related output port is disconnected, otherwise connected.

10 or 110: frequency detection 1

When inverter output frequency reaches or exceeds the sum of frequency detection speed (P06.19) value and frequency detection width (P06.20) value, frequency detection 1 is triggered. After the related output port action, when inverter output frequency drops back to the frequency detection speed (P06.19), frequency detection 1 is reset.

10: When the frequency detection 1 is acting, related port is disconnected

110: When the frequency detection 1 is acting, related port is connected

11 or 111: frequency detection 2

When inverter output frequency reaches or exceeds the value of frequency speed detection (P06.19), frequency detection 2 is triggered. After the related output port action, when inverter output frequency drops back to the result of frequency detection speed (P06.19) minus frequency detection width (P06.20), frequency detection 2 is reset.

10: When the frequency detection 2 is action, related port is connected

110: When the frequency detection 2 is action, related port is disconnected

12 or 112: fault predicting

12: during fault predicting, related port is connected, otherwise disconnect

112: during fault predicting, related port is disconnected, otherwise connect

13 or 113: inverter alarm

13: inverter alarms, but doesn't stop due to the fault, related port is connected, otherwise disconnect

113: inverter alarms, but doesn't stop due to the fault, related port is disconnected, otherwise connect

14 or 114: direction detection at zero servo torque (for emergent leveling at power failure)

14: inverter tests heavy load, light counter-weight, related port is connected, otherwise disconnect

114: inverter tests heavy load, light counterweight, related port is disconnected, otherwise connect

15 or 115: zero current detection

15: inverter output current is greater than non zero current detection threshold (P06.18) while stopping, related port is connected, otherwise disconnect

115: inverter output current is greater than non zero current detection threshold (P06.18) while stopping, related port is disconnected, otherwise connect

Remark: “connected” means: for relay output, NO contacts (1B and 1C, 2B and 2C) are connected. NC contacts (1B and 1A, 2B and 2A) are disconnected. For open collector output, the output is under low level status. And the same for “disconnected”: for relay output, NO contacts (1B and 1C, 2B and 2C) are disconnected. NC contacts (1B and 1A, 2B and 2A) are connected. For open collector output, the output is under high resistance status.

Note2: Factory setting: P06.02 = 3, specified the port Y0 as the running signal output (RUN); P06.03 = 2, specified the port Y1 as the fault signal output.

Note 3: Run signal (RUN)

Only when the inverter receives up/down going command signal, and the base doesn't block, will the run signal (RUN) be sent.

Note 4: Fault signal sequence

When inverter fault occurs, fault signal is output. At the same time, run signal is cleared. Fault signal is locked and can only be cleared when it is input an external reset signal, executed a reset command from operator, power disconnected or set an internal delay time.

The sequence of fault signals, see Fig. 6.9.



Fig. 6.9 Fault signal sequence

Note 5: Setting for the delay of output and reset at output terminal

P06.06 ~ P06.17 are constants for the setting of action delay time and reset time of 6 outputs K1 ~ K2 and Y0 ~ Y3. Individual output state and delay time can be easily set corresponding to their related actual signal. All above delay time can be set respectively either in signal triggering or resetting.

Note 6: Inverter non-zero current detection threshold

P06.18 sets the value of inverter non-zero current detection threshold. When inverter current is greater than this threshold at stop, related output action can be set by function code 15 (or 115) . It is a necessary function for the system with only one contactor in main circuit. Requested by the criteria of GB7588, a monitoring device is needed to monitor whether the current flows or not while elevator stops, if there is only one contactor used to cut off the current of traction motor. And once flowing current is found in motor when elevator stops, is the contactor controlled to release and prevent re-starting of elevator. To use this non-zero current detection function well can easily meet the criteria of GB7588. Refer to chapter 7, 7.9.4 for details.

Note 7: Frequency detection

P06.19 and P06.20 are two parameters for frequency detection: frequency detection speed and frequency detection width. The combination of these two parameters is used for frequency detection 1 and frequency detection 2. It used to detect whether the output frequency of inverter is in a designated range. In frequency detection 1, when inverter output frequency reaches or exceeds the sum of frequency detection speed value (P06.19) and frequency detection width value (P06.20), frequency detection 1 is triggered. After related output port action, and when inverter output frequency drops back to the frequency detection speed (P06.19), frequency detection 1 is reset. Frequency detection is negative logic, output state is OFF when triggered, output state is ON when reset.

In frequency detection 2, when inverter output frequency reaches or exceeds the value of frequency detection speed (P06.19), frequency detection 2 is triggered. After related output port action, when inverter output frequency drops back to the result of frequency detection speed value (P06.19) minus frequency detection width value (P06.20), frequency detection 2 is reset. Frequency detection is positive logic, output state is ON when triggered, output state is OFF when reset. Fig. 6.10 and Fig. 6.11 are diagrams for frequency detection 1 and frequency detection 2.

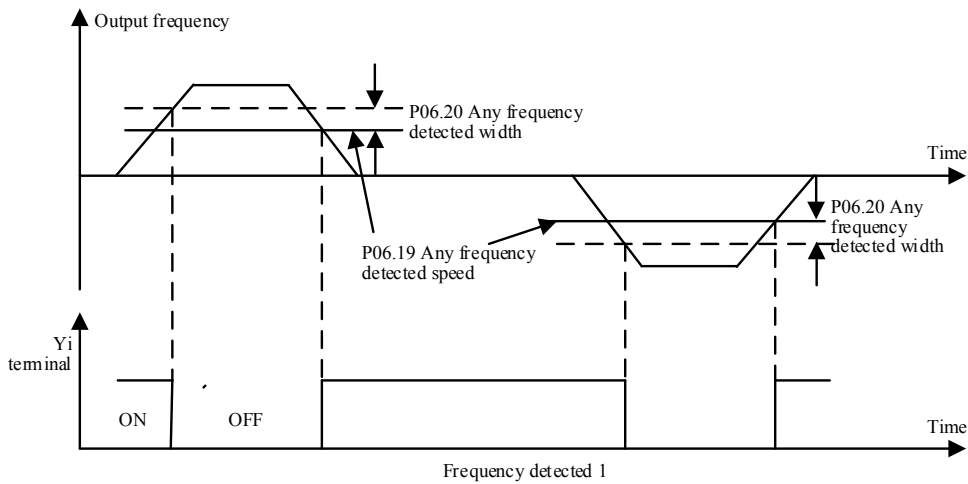

Fig. 6.10 Diagram for frequency detection 1

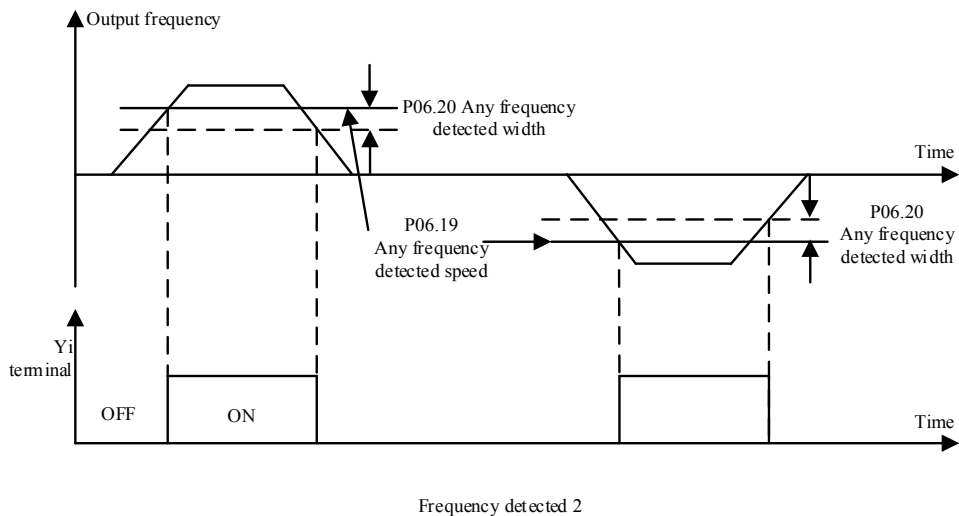

Fig. 6.10 Diagram for frequency detection 2

6.2.8 Analog input function parameters

Parameter group P07 defines the function of analog input terminal and their related features.

Function code	Name	Content	Setting range	Unit	Factory default	Remarks
P07.00	AI0 analog input type	Set types of analog input AI0 ~ AI1: 0: 0~10V 1: -10V~10V	0/1	×	1	
P07.06	AI1 analog input type				1	
P07.01	AI0 analog input function	Set functions of analog input AI0 ~ AI1: 0: Invalid (unused port) 2: Analog speed reference 3: Analog torque reference 4: Analog torque compensation reference	0/2/3/4	×	2	The factory default setting for AI0 is analog speed reference
P07.07	AI1 analog input function				0	The factory default setting for AI1 is analog torque compensation
P07.02	AI0 analog input offset	Set offset voltage for AI0 analog input	0.000 ~ 20.000	V	10.000	
P07.03	AI0 analog input gain	Set gain value for AI0 analog input, it is a percentage data	0.0~ 100.0	%	100.0	
P07.04	AI0 analog input filtering time	Set filtering time for AI0 analog input signal	0~30	ms	10	
P07.05	AI0 analog input voltage limit	Set voltage limit for AI0 analog input	0.000 ~ 10.000	V	10.000	
P07.08	AI1 analog input offset	Set offset voltage for AI1 analog input	0.000 ~ 20.000	V	10.000	
P07.09	AI1 analog input gain	Set gain value for AI1 analog input, it is a percentage data	0.0~ 100.0	%	100.0	
P07.10	AI1 analog input filtering time	Set filtering time for AI1 analog input signal	0~30	ms	10	
P07.11	AI1 analog input voltage limit	Set voltage limit for AI1 analog input	0.000 ~ 10.000	V	10.000	

Note 1: Definition of analog input type

P07.00 and P07.06 are parameters for the definition of analog input AI0 and AI1. Type of analog input is decided by hardware. This inverter uses the type of -10V ~ 10V. A default value 1 is used in this case for both of them and don't need to modify.

Note 2: Definition of analog input function

P07.01 is a parameter for the function of first analog input AI0, P07.02 is a definition parameter for the function of second analog input AI1. In most control system special for elevator, AI0 is set as input port for analog speed reference. Therefore the factory default value for P07.01 is set to 2. Please notice, to make AI0 actually become an analog speed reference input port successfully, beside setting P07.01 to 2, P03.00 must also be set to 4 (select analog speed reference mode).

Note 3: Setting related parameters for analog input port AI0

P07.02 is a zero offset calibration for analog input port AI0. The setting value can be calculated by following formula:

$$P07.02 = 10.000 - \text{actual zero offset of analog input port AI0 (minimum input)}$$

For example: Zero offset of analog input AI0 is 0.010V, then

$$P07.02 = 10.000 - 0.010 = 9.990$$

Normally the minimum value of analog input AI0 is 0, therefore P07.02 is set to 10.000 as factory default.

P07.03 is a gain value for analog input port AI0. If actual operation speed require to reduce to only 90% of rated speed, set $P07.03 = 90.0$

P07.04 is the filtering time for analog input port AI0. Default is 10. It means 10 ms filtering. To increase filtering time appropriately can suppress analog input signal interference efficiently if input signal is interfered. But too long a filtering time may cause the input signal lag.

P07.05 is the input voltage limit for analog input port AI0. After processing of offset and gain above-mentioned, if the value of analog voltage input AI0 is greater than the voltage limit of P07.05, it should be limited. 10V is the maximum AI0 value (such as elevator rated speed) for related signal after offset and gain, the limit value of P07.05 is meaningless in this case if it is over 10V. In addition, this data is always set to 10V by default and don't need to be modified in specific elevator control system.

Note 4: Analog input port AI1 has the same setting and function as AI0.

6.2.9 Analog output function, LCD and LED content display

parameters

In parameter group P08, it can set the function of analog output terminal and their related features. It can also select the display content on LCD or LED.

Function code	Name	Content	Setting range	Unit	Factory default	Remarks
P08.00	Analog output M0 function	Set function of analog output M0 ~ M1 0: No defined 1: U phase current 2: V phase current 3: W phase current 6: Speed reference 7: Feedback speed	0~44	×	1	
P08.01	Analog output M1 function	13: Speed regulator output 14: Current regulator IQ reference 15: Current regulator ID reference 30: Current regulator IQ output 32: DC bus voltage 44: Speed deviation			2	
P08.02	M0 analog output offset	Set voltage offset value of M0 analog output	0.000 ~ 20.000	V	15.000	
P08.03	M0 analog output gain	Set the gain value of M0 analog output	0.0 ~ 1000.0	%	100.0	
P08.04	M1 analog output offset	Set voltage offset value of M1 analog output	0.000 ~ 20.000	V	15.000	
P08.05	M1 analog output gain	Set the gain value of M1 analog output	0.0 ~ 1000.0	%	100.0	
P08.06	Select the data of U01 displayed in LCD	Operator has LCD and LED screen. LED displays one number, LCD can display 8 numbers from U01 ~ U08. The definition of parameters are:	0 ~ 31	x	24	
P08.07	Select the data of U02 displayed in LCD	0: No definition			1	
P08.08	Select the data of U03 displayed in LCD	1: Feedback rpm (rpm) 2: Speed reference (Hz) 3: Feedback speed (Hz)			25	
P08.09	Select the data of U04 displayed in LCD	4: Output current (A) 5: Output voltage (V) 6: Output torque (%)			4	
P08.10	Select the data of U05 displayed in LCD	7: Bus voltage (V)			6	
		8: Analog input 1 signal (V) 9: Analog input 2 signal (V)				

Function code	Name	Content	Setting range	Unit	Factory default	Remarks
P08.11	Select the data of U06 displayed in LCD	13: Magnetic pole angle at static self-learning 16: Zero servo torque (%)			16	
P08.12	Select the data of U07 displayed in LCD	17: Numbers of interference on encoder Z phase 18: Times of interference on encoder A, B phase			7	
P08.13	Select the data of U08 displayed in LCD	23: Weighing compensation torque (%)			5	
P08.14	Select data displayed in LED	24: Rpm reference (rpm) 25: Speed deviation (rpm) 26: Weighing compensation percentage (%) 27: The encoder C phase center 28: The encoder D center 29: Radiator temperature (°C)			1	
P08.15	Set the ID of the inverter	0~32 are corresponding to the different inverter ID	0~32/90		90	It's a special parameter. If it's inconsistent between the power displayed on the manipulator and the inverter nameplate, please consult factory.

Note 1: Definition for analog output port

Parameter P08.00 and P08.01 define the function of analog output port M0 and M1. Above table lists the detail meanings of specific function codes. The voltage range of analog output M0 and M1 is -10V ~ 10V. Normally if related signal is 0, the voltage of analog output is 0V; if related signal is maximum, the voltage of analog output is 10V.

Note 2: Selection on analog output offset, gain

P08.02 and P08.04 are offset parameters for analog output M0 and M1. The value is defined by hardware. Default value is 15V and don't need to modify normally.

P08.03 and P08.05 are gain parameter for analog output M0 and M1. Default gain value 100% should be taken. If it is less than 100%, analog voltage output can't reach 10V and output voltage width at analog port can't be fully used. If selected gain is greater than 100%, analog voltage output reaches the maximum 10V even the signal doesn't reach its maximum value. In this case analog output signal can't display the status of whole related signal.

Note 3: Operator LCD data display setting

P08.06 ~ P08.13 can set 8 data (U01 ~ U08) to be displayed on operator LCD. Three data can

be displayed on LCD screen simultaneously: U01 ~ U03 on first screen, U04 ~ U06 on second screen, U07 ~ U08 on third screen.

Note 4: Operator LED data display setting

P08.14 sets the data displayed on LED. The function code are same as the 8 codes in LCD selection.

6.2.10 Other information

Function code	Name	Content	Setting Range	Unit	Factory default	Remarks
P09.00	Accumulated power ON time	View Accumulated power ON time		h		Read only
P09.01	Accumulated operation time	View Accumulated operation time		H		Read only
P09.02	Max. Temperature of radiator	View Max. Temperature of radiator		℃		Read only
P09.03	Hardware version	View Hardware version		×		Read only
P09.04	Control panel software version	View Control panel software version		×		Read only
P09.05	Inverter rated power	View Inverter rated power		KW		Read only
P09.06	Torque direction				1	
P09.07	Electric current loop Kp				1.40	
P09.08	Electric current loop Ki				1.00	
P09.09	Electric current loop Kd				0.00	
P09.10	Bandwidth of Electric current loop			Hz	400.00	
P09.11	Bandwidth of magnetic linkage loop			Hz	0.8	
P09.12	Electric current loop selection				0	
P09.13	Reserved					
P09.14	Filtering time by electric current loop reference (reserved in latest program version)	Not required to modify normally		ms		

Function code	Name	Content	Setting Range	Unit	Factory default	Remarks
P09.15	PWM modulation mode	0: 5 section; 1: 7 section; 2: <40%rpm 7 section, >40% 5section	0~2		1	
P09.16	Zero servo compensation		0~100	%	0	
P09.17	Delay of contactor connecting			S	0.8	
P09.18	Braking release delay			S	0.4	
P09.19	Contactor disconnecting delay			S	1.0	
P09.20	Braking delay			S	0.1	
P09.21	Output disconnecting delay			S	0.3	
P09.22	Zero speed threshold			Hz	0.20	
P09.23	Special function selection				0	
P09.24	Three phase current balance coefficient				1.043	
P09.25	Minor fault handling	0: Relay doesn't output fault 1: Relay outputs fault			1	
P09.26	Automatic fault reset time			S	10.0	
P09.27	Automatic fault reset count				3	
P09.28	radiator over heat time			S	0.50	
P09.29	Coefficient of over-speed protection			%	120.00	
P09.30	Time of over-speed protection			S	1.00	
P09.31	Voltage threshold for input missing phase			V	55	
P09.32	Braking resistor short times			Times	10	
P09.33	Proof of encoder disconnection			Times	2	
P09.34	Proof of output missing phase			S	2.000	
P09.35	Relay fault voltage			V	65	
P09.36	Encoder fractional	0: (No frequency division);	0~7		0	

Function code	Name	Content	Setting Range	Unit	Factory default	Remarks
	frequency coefficient (supporting PG card required)	1: (2 frequency division); 2: (4 frequency division); 3: (8 frequency division); 4: (16 frequency division); 5: (32 frequency division); 6: (64 frequency division); 7: (128 frequency division) (Note: need the PG card to support)				
P09.39	Angle self-learning for synchronous motor when power on	Select whether proceed self-learning of angle when the synchronous motor power on, 0: not learn; 1: learn	0/1		0	
P09.40	Current gain at self-learning	Current gain for angle self-learning of the synchronous motor	0~400	%	150	
P09.41	Threshold for encoder CD phase fault	If the difference value between encoder absolute position and calculated position is over this set value, fault No. 28 will be reported	0~6553 5		300	
P09.43	Threshold for ABZ encoder disconnect protection	Protecting when the speed feedback deviation of synchronous motor is over this value	0~100	%	20	
P09.44	IGBT protection times		1~6553 5	Times	2	
P09.45	I _{2t} protection selection		0~6553 5		0	
P09.46	ID_0	Inverter internal parameter, not modifiable				
P09.47	ID_1	Inverter internal parameter, not modifiable				
P09.48	ID_2	Inverter internal parameter, not modifiable				
P09.49	ID_3	Inverter internal parameter, not modifiable				
P09.50	ID_4	Inverter internal parameter, not modifiable				
P09.51	ID_5	Inverter internal parameter, not modifiable				

Function code	Name	Content	Setting Range	Unit	Factory default	Remarks
P09.52	ID_6	Inverter internal parameter, not modifiable				

P09.04 – No. 3 output function can be used to control the brake. The recommended parameters set as follows: , firstly set P09.04 = 261.66, only after the first set ,can the below parameters be set; then start to set followings: P12.00=3, P12.01=2.00Hz, P12.02=0.5S, P12.06=3S, P09.22=0.3HZ. Parameters P12.01、 P12.02、 P12.06、 P09.22 can be adjusted on site base on the leveling requirement.

P09.36 – encoder frequency division coefficient. The parameter selects the coefficient of PG card frequency division, the default value is 0. Needs the support of the PG with the frequency division function. The parameter has these selections: 0 (no frequency division); 1 (2 frequency division); 2 (4 frequency division); 3 (8 frequency division); 4 (16 frequency division); 5 (32 frequency division); 6 (64 frequency division); 7 (128 frequency division).

P09.39 – optional self-learning selection for synchronous motor when power on. Default is 0. If self-learning has been done, it wouldn't do it again by power on (only for SIN/COS encoder and Endat encoder). Phase angle P01.17 can be manually modified. If P01.17 is 0, self-learning will start automatically after providing operation command from inverter. If P01.17 is 1, self-learning will start each time when power on. Note that after P09.39 being set to 0, P01.17 needs to set to 0 and to do a self-learning if motor or encoder is replaced. Otherwise motor might run over-speed due to the wrong phase angle. Synchronous self-learning is a static self-learning. The brake can't be released during self-learning, otherwise the phase angle of self-learning would not correct.

P09.40 – current gain during self-learning. Factory default is 150. It means the default 1.5 times of rated current is used for phase self-learning. For adjusting special drive (such as Boma drive) on site, several times of phase self-learning can be done. After self-learning, drive needs to run a circle. The position of phase angle can be seen in parameter P01.17. If P01.17 is set to 0, drive will do self-learning without power off. Comparing the value of P01.17 after each self-learning, if the value is over the range of +10V ~ -10V, increase P09.40 and try it again until the self-learning deviation value reduce into the range. The value of P09.40 should not be too big, or the first time motor running will have noise after self-learning. It is OK to set the value under 300. At testing job site Boma drive was set to 250 and do self-learning to make the deviation of phase angle is within 8.

P09.41 – threshold for encoder CD phase failure. Default value is 300. If the difference of encoder absolute position and calculated position is over this value, fault 28 is reported. If no self-learning by power on (F09.39=0) is selected, inverter will do encoder C/D phase checking automatically. If the position of C/D phase is incorrect, over the threshold set by P09.41 , the fault 28 will be reported. Need to pay special attention on site, changing P09.39 from 1 to 0 may cause fault 28, because when set P09.39 = 1 the position of C/D phase would not be checked, broken wiring or wrong connection is irrelevant in this case. This fault check is only for SIN/COS encoder and Endata encoder.

P09.43 – threshold for ABZ encoder disconnect protection. The default value is 20%. Inverter reports fault 12 if synchronous motor uses ABZ encoder and the feedback speed deviation exceeds this protection threshold, the encoder is regarded as disconnected.

Chapter 7 Elevator Operation Guide

7.1 Introduction

A320 series inverter is specific developed for elevator drive. It uses the advanced vector control technology and has excellent capability on speed adjustment. Since this product is special for elevator designed, the adjustment and operation is very simple, easy to adjust the each running sections and reaches the best performance.

The flow chart of internal controlling of AS320 series inverter is referred to Fig. 7.1

A whole elevator electrical control system can be divided in to two systems, control and drive. Control system is responsible for the sequential control of elevator starting, braking, and controlling of all elevator automatic operation functions. Some control system provides speed command curve for elevator operation. Drive system is mainly responsible for the speed control of elevator traction motor, to ensure a smooth speed changing during the whole running and make the passengers get well comfortable riding. Drive system also has a function of calculating speed command curve. In multi-section speed reference, drive system creates speed curve automatically based on the target speed section provided by control system. The main task of drive system is to control motor running under speed command curve strictly in any speed reference mode. AS320 series inverter is a typical elevator drive system. So it needs to combine to a specific elevator control system and becomes a complete elevator electrical control system. Control system specified for elevator SMART COM from STEP, or other similar elevator control systems, can match this inverter.

During the period applying AS320 series inverter into elevator control system, speed reference mode (analog or multi-section) must be selected firstly according the characteristic of elevator controller. Secondly the circuit needs to be designed based on the signal communication requirements between inverter and elevator controller. Then the basic parameters are set according the requirement. A running of parameter self-learning is needed if it is an asynchronous motor. Lastly on-site adjustment is performed for running direction, speed curve and riding comfort. Following diagram shows this process:

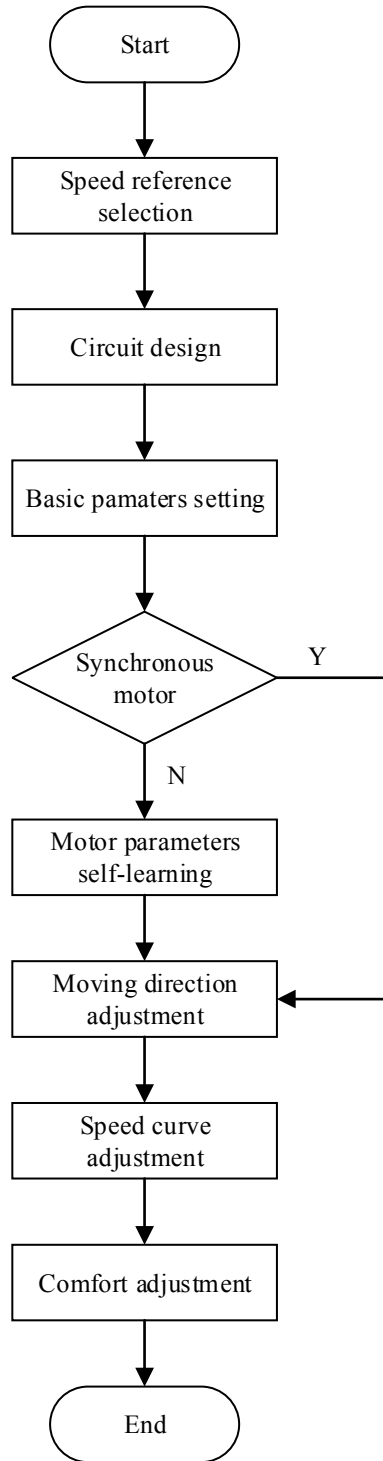

Following sections in this chapter introduce the contents of above process. For your reference, last section introduces several optional functions.

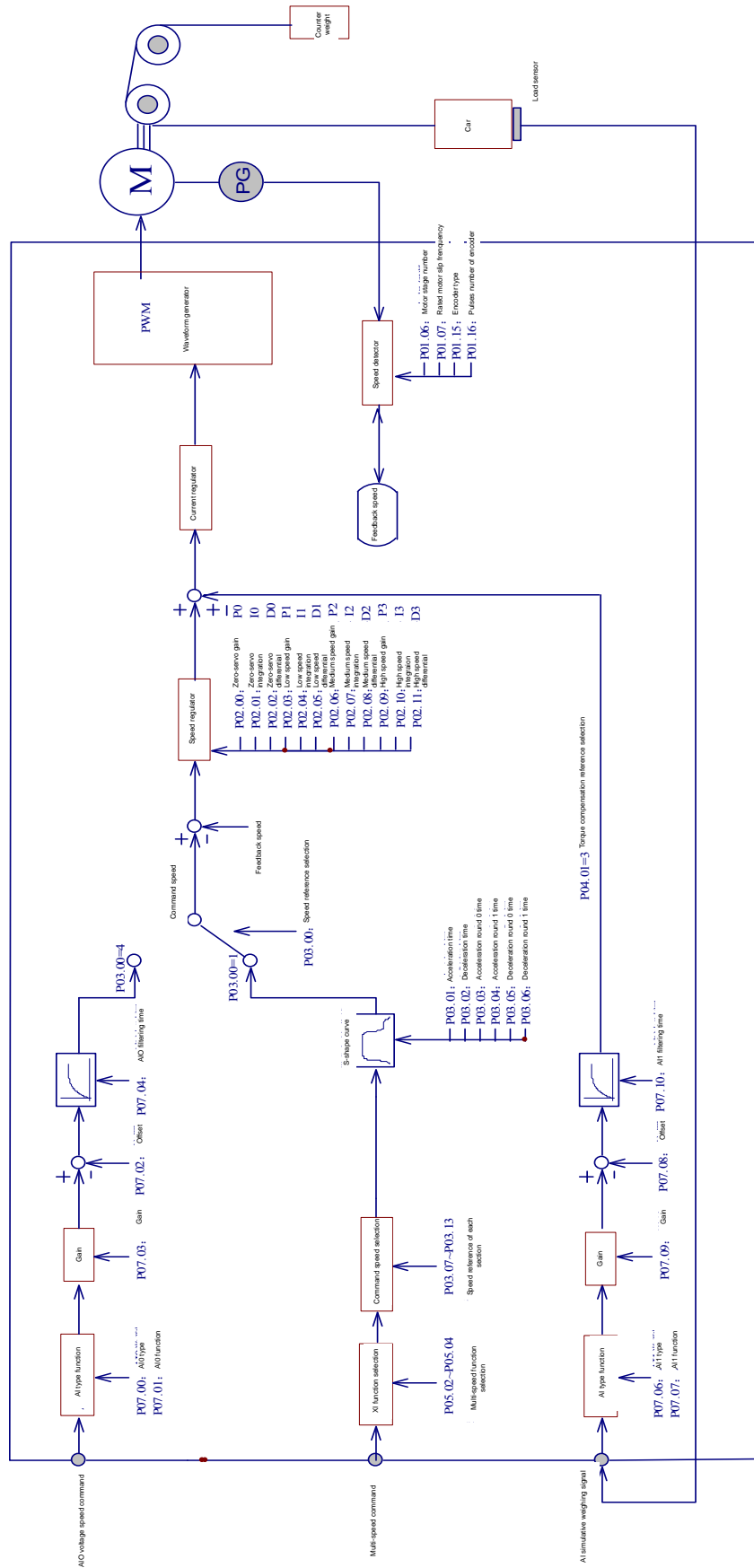

Fig. 7.1 Inverter internal control chart

7.2 Description of speed reference mode

There are two types of speed reference for AS320 series elevator inverter: analog speed reference and multi-section speed reference. In analog speed reference mode, elevator controller generates speed command curve. Its signal is sent from analog output port into inverter analog input port. Inverter receives elevator speed reference command by getting the value of analog input signal instantaneously during each elevator operation. In multi-section speed reference mode, elevator controller doesn't need to provide a detail speed curve. In elevator operation, controller produces a binary code signal through digital output signal, and sends inverter a speed section command (target speed command). Inverter will generate a S-shape speed curve automatically from previous speed command to new speed command after receiving this speed section command. Elevator will then be controlled to move strictly follow the S-shape curve. The analog speed reference mode of AS320 series elevator inverter is the speed reference mode of analog voltage signal. Inverter input port AI0 inputs voltage signal from 0 ~ 10V, corresponding to the speed reference command from 0 to maximum speed.

In general, if controller can provide speed reference curve, and has analog output matching AS320 series elevator inverter, we recommend to use analog speed reference mode. If controller doesn't have analog output which can match AS320 inverter, or can't provide speed reference curve, multi-section speed reference mode should be taken. Comparing with analog speed reference, multi-section speed reference mode is more complicate to use. Furthermore, if elevator controller can generate speed curve by using distance deceleration formula during decelerating, using analog speed reference mode will not only simplify the adjustment, but also make elevator stop directly and improve the operation efficiency.

In multi-section speed reference mode, once inverter receives a speed section command, it will generate a S-shape curve with the goal of this speed section, and with the time as the variable, based on acceleration/deceleration slope (parameters of acceleration time and deceleration time) and S round corner parameter (acceleration round time and deceleration round time). In this mode, the deceleration distance is decided by elevator controller parameter when elevator runs at a certain speed. If actual running speed matches S-shape speed command curve perfectly, elevator can achieve the direct stop during each decelerating. That means the elevator speed reduces to zero and elevator is located perfectly in level position according to the speed curve. In this case the elevator operates in optimal efficiency. But in reality, elevator load and moving direction keeps changing, no inverter can reach an absolute match between actual speed and speed reference. So the actually decelerating distance may vary in different situation. In order to assure elevator do not exceeding leveling position (passenger may complain), deceleration distance needs to be adjusted to the maximum to avoid this happen in any circumstance by actual adjustment. In some case, elevator will run in creeping if the actual deceleration distance is short. It will affect the efficiency. If distance deceleration is used, speed is followed by different situation. Speed reference curve is finely modified based on the actual operate status. It ensures that elevator can stop directly under any circumstance and reaches the optimal operation efficiency.

7.3 Description of connection between elevator control and inverter

There are two kinds of signal communication between elevator controller and AS320 series elevator inverter. One kind is the signal sent from elevator controller to inverter. It includes up, down going commands, speed reference command; other kind is the signal sent from inverter to elevator controller, which includes operation signal, fault signal, and encoder pulse signal after processed by PG card. Because there are two different speed reference modes, the wirings of the speed reference would be slightly different. The following two sections introduce the possible wiring diagram for these two different speed reference modes. Encoder wiring may also vary to different PG card. If the PG card taken isn't same with the following example, please refer to [chapter 4.6 Terminal wiring of PG card](#).

7.3.1 Reference diagram for wiring in analog speed mode

Fig. 7.2 shows the wiring diagram for analog speed reference mode for your reference.

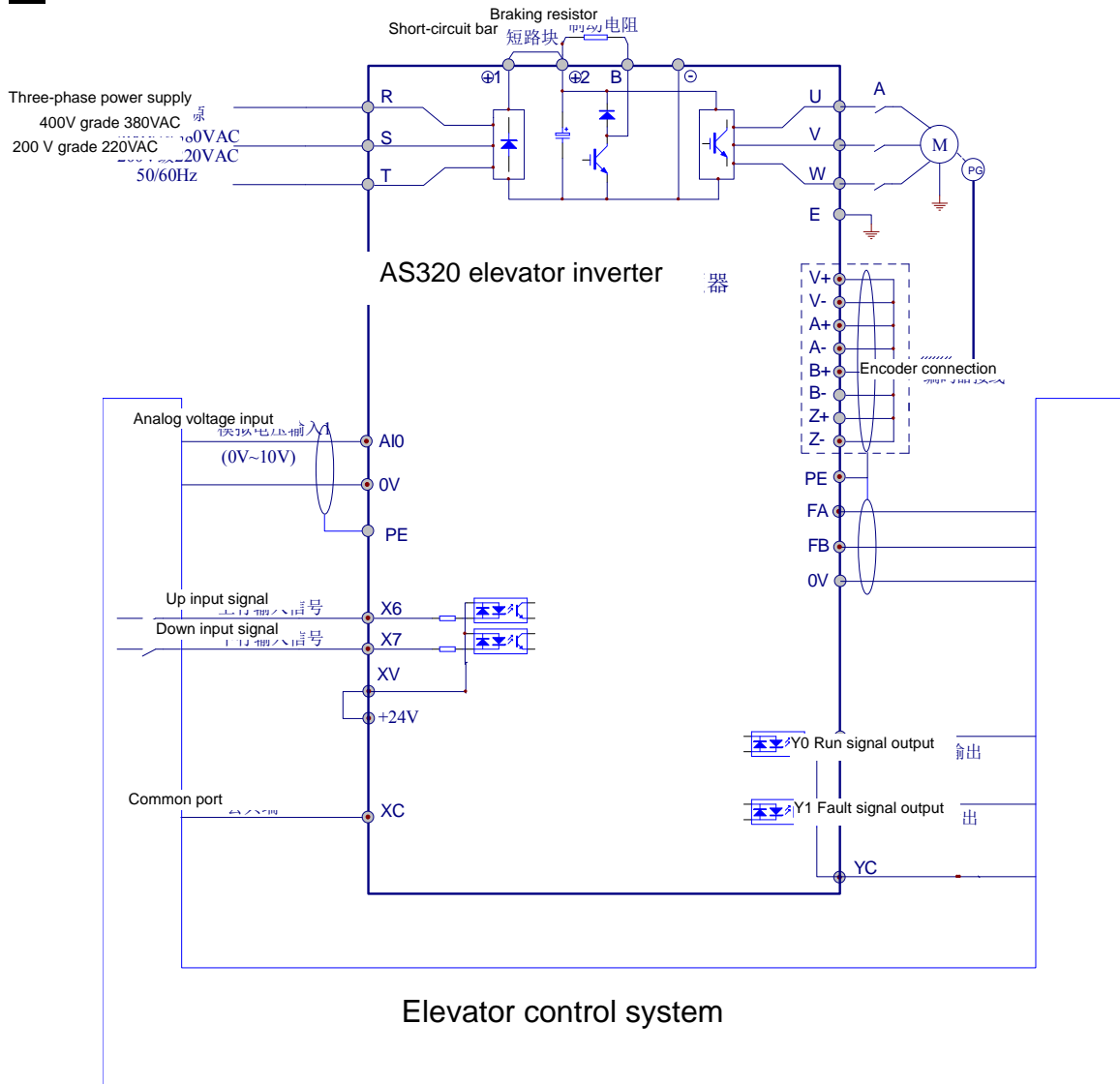

Fig. 7.2 Reference diagram for basic circuit of analog voltage signal speed reference mode

Terminal blocks in diagram are defined in Table 7.1.

Table 7.1 Inverter terminal definition in analog speed reference mode

Terminal	Name	Types of signal
X6 (Factory setting)	Up going signal	Input signal
X7 (Factory setting)	Down going signal	Input signal
A0	Analog voltage input 0~10V	Input signal
0V	Analog 0V	Input signal
Y0 (Factory setting)	Operation signal	output signal
Y1 (Factory setting)	Fault signal	output signal

Note: The terminals of the up, down going input signal, operation output signal and fault output

signal are all set as in the above table before leaving factory. Ports are normally not need to redefine by modifying parameter. In some special requirement, input ports can be redefined by modifying digital input parameters (refer to chapter 6.2.6), output ports can be redefined by modifying digital output parameters (refer to chapter 6.2.7). The content in above table needs also to be amended after terminal port redefined.

7.3.2 Reference wiring diagram for wiring in multi-speed mode

Fig. 7.3 shows the wiring diagram for multi-section speed reference mode for your reference.

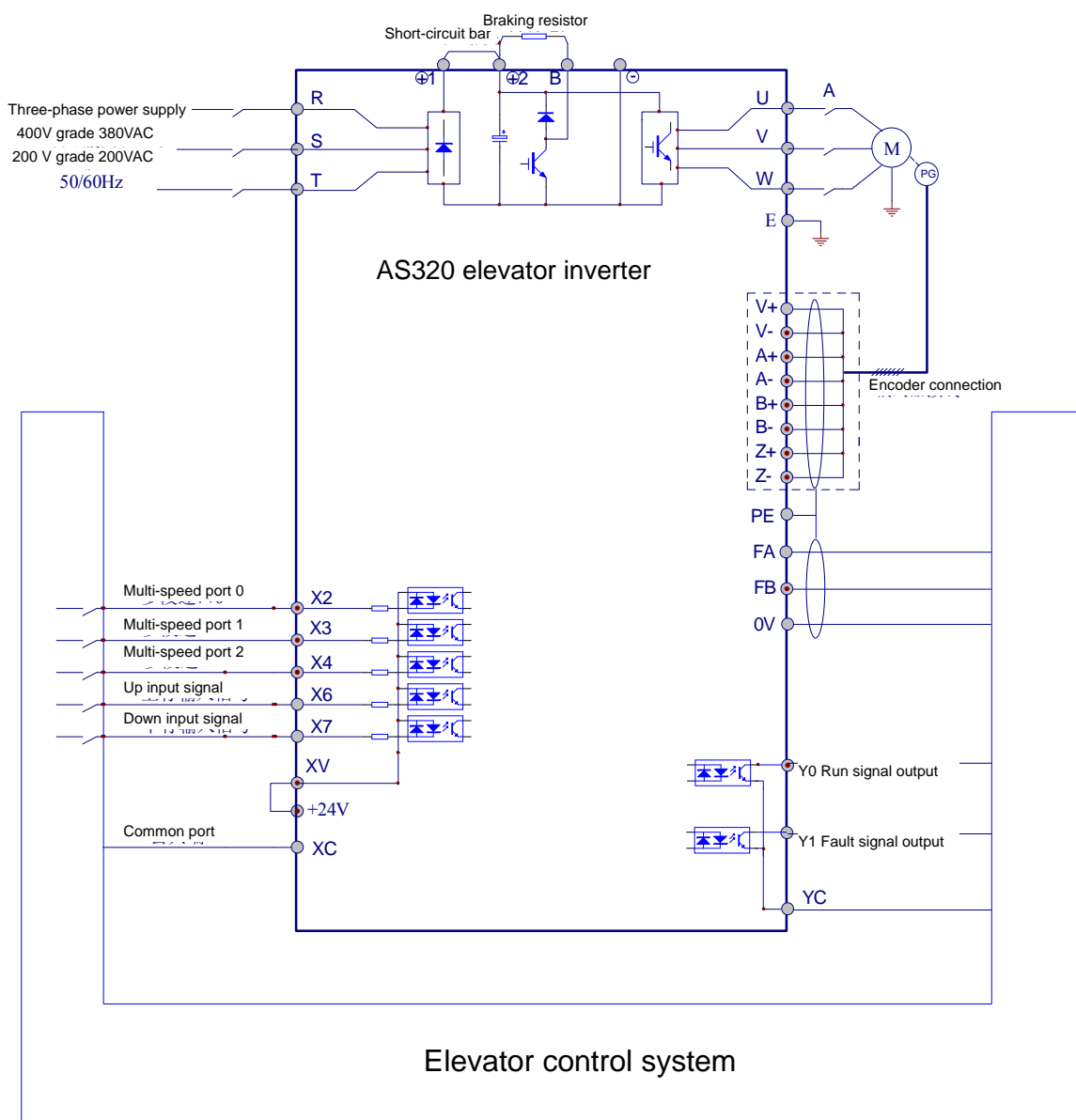

Fig. 7.3 Reference wiring diagram for basic circuit of multi-section speed reference mode

Terminal blocks in diagram are defined in Table 7.2.

Table 7.2 Inverter terminal block definition in multi-section speed reference mode

Terminal	Name	Types of signal
X2(Factory setting)	Multi-section speed reference port 0	Input signal
X3(Factory setting)	Multi-section speed reference port 1	Input signal
X4(Factory setting)	Multi-section speed reference port 2	Input signal
X6(Factory setting)	Up going signal	Input signal
X7(Factory setting)	Down going signal	Input signal
Y0(Factory setting)	Operation signal	Output signal
Y1(Factory setting)	Fault signal	Output signal

Note: Up, down going input signal, multi-section speed reference input 0~2, operation output signal and fault output signal are all set as this table before leaving factory. Ports are normally not need to redefine by modifying parameter. In some special requirement, input ports can be redefined by modifying digital input parameters (refer to chapter 6.2.6), output ports can be redefined by modifying digital output parameters (refer to chapter 6.2.7). The content in above table needs also to be amended after port redefinition.

Multi-section speed reference ports input by digital input port can combine to 8 states. These 8 states correspond to the speed 0 and other 8 reference speed in P03.07 ~ P03.13. They are 8 section speed reference commands. The following table provides the relationship of multi-section terminal input versus speed reference.

Multi-section speed code combination	Multi-section speed reference port 2	Multi-section speed reference port 1	Multi-section speed reference port 0	Speed reference
0	0	0	0	0
1	0	0	1	Speed reference 1 (Function code P03.07)
2	0	1	0	Speed reference 2 (Function code P03.08)
3	0	1	1	Speed reference 3 (Function code P03.09)
4	1	0	0	Speed reference 4 (Function code P03.10)
5	1	0	1	Speed reference 5 (Function code P03.11)
6	1	1	0	Speed reference 6 (Function code P03.12)
7	1	1	1	Speed reference 7 (Function code P03.13)

7.4 Basic parameter setting

For each project, basic parameters must be set based on the specifications of traction motor and encoder before inverter is operated. Since AS320 series elevator inverter is specifically developed for elevator, the actual elevator operation requirements are fully considered, most of factory set (default) parameters can be taken directly without modifying. The required modification of parameters on-site is far less than introduced here. Therefore it's pretty simply to set parameters on-site for this inverter. This chapter introduces those basic parameters which must be set according the specifications of elevator traction motor and encoder before operation. Motor parameters self-learning, test running and tuning of operation performance can only start after these basic parameters have been set. Tuning parameters will be introduced in the following section. It must be emphasized that beside the following setting parameters, all other basic parameters are taken their factory default setting. It is recommended to have a reset operation before starting to set parameters. This procedure will ensure that all parameters are back to the default value. Method of reset parameters: entering the parameter setting screen in operator, screen displays "Init=0", changing 0 to 7 and then pressing Enter, reset password (same as login password). Screen shows "Reset success". All parameters are set to their factory default. End of reset operation.

7.4.1 Speed reference mode setting

There is only one parameter for speed reference mode: P03.00. The following table shows that three modes of speed references, analog speed reference input AI0, analog speed reference input AI1 and multi-section speed reference, are set by P03.00. Analog speed reference input AI0 is not taken in actual operation.

Function code	Name	Content	Setting range	Unit	Factory default	Remarks
P03.00	Speed reference mode	0: Panel setting 1: digital controlled multi-section speed reference 4: analog speed reference AI0 6: analog speed reference AI1	0 / 1 / 4 / 6	×	4	

7.4.2 Traction motor setting

Parameter group P01 are the specifications of elevator traction motor and encoder. These parameters are very important for inverter. A wrong setting can cause elevator vibration, or even inoperation, till an incident of equipment damage. It is a must to follow the nameplate data, set each parameter carefully. Normally only P01 parameters in following table need to be set, other data are obtained automatically by motor self-learning, default value. Some of parameters need to be decided during operation and tuning whether it should be adjusted or not. If inverter is changed (only for

asynchronous motor) and new inverter doesn't take a self-learning, P1 group parameter in old inverter which has already done self-learning procedure can be recorded and set into new inverter.

Function code	Name	Content	Setting range	Unit	Factory default	Remarks
P01.00	Motor type	0: Asynchronous 1: Synchronous	0/1	×	1	
P01.01	rated motor power	Set rated motor power	0.40~ 160.00	KW	Based on inverter specificati on	Set follow motor nameplate
P01.02	Rated motor current	Set rated motor current	0.0~ 300.0	A	Based on inverter specificati on	Set follow motor nameplate
P01.03	Rated motor frequency	Set rated motor frequency	0.00~ 120.00	Hz	50.00	Set follow motor nameplate
P01.04	Rated motor rpm	Set rated motor rpm	0~3000	rpm	1460	Set follow motor nameplate
P01.05	Rated motor voltage	Set rated motor voltage	0~460	V	Based on inverter specificati on	Set follow motor nameplate
P01.06	Motor poles	Set motor number of poles	2~128	×	4	Set follow motor nameplate
P01.07	Rated motor slip frequency	Set rated motor slip frequency	0~10.00	Hz	1.40	Set follow motor nameplate
P01.15	Encoder type	0: Incremental encoder 1: SIN/COS encoder 2: Endat encoder	0/1/2	×	0	
P01.16	Encoder pulse number	Number of pulse per encoder cycle	500~ 16000	PPr	1024	
P01.17	The phase Angle of the encoder	The encoder phase Angle value	0.0~ 360.0	度	0.0	The data automatically obtained when the inverter runs at the first time after power on, which is only effective for the synchronous motor.
P01.18	The encoder	Set the filter time constant when	1~30	ms	0	

Function code	Name	Content	Setting range	Unit	Factory default	Remarks
	filtering time	inputting the encoder feedback speed				
P01.19	The direction of the encoder feedback	Set the direction of the encoder feedback speed. 1: Positive sequence 0: Negative sequence	0 / 1	×	1	
P01.20	Inverter input voltage	Set the input voltage of inverter	0~460	V	380	Can only be manually set

Note 1: Motor poles

P01.06 is used to set the motor poles. It should follow the nameplate.

Poles can be calculated by this formula if nameplate doesn't have number of poles

$$\text{Pole number} = (120 \times f) \div n$$

n: rated rpm;

f: rated frequency

A rounded even integer is taken from the calculation, it is the number of poles.

Note 2: Setting slip frequency

If motor nameplate doesn't include data of slip frequency, P01.07 data can be retrieved by following calculation:

Assume that: Rated frequency f (P01.03), rated rpm n (P01.04), motor poles p (P01.06)

Then: slip frequency = $f - ((n \times p) \div 120)$

For example: rated frequency f = 50Hz, rated rpm n = 1430 rpm, motor pole = 4

The value of P01.07 = $50 - ((1430 \times 4) \div 120) = 2.33\text{Hz}$

7.5 Motor parameters self-learning guide

This inverter has its original technology and doesn't require for a motor self-learning for synchronous motor. Inverter can obtain encoder phase angle automatically as long as following the previous parameter setting. That means this section can be skipped if synchronous motor is use as a traction drive.

Please note that 2 seconds time is needed to obtain encoder information automatically for each time when the first power on if the inverter controls synchronous motor. At that time a run signal will output later than ordinary operation. In order to avoid unnecessary fault, this delay must be considered when designing control system.

For asynchronous motor, it doesn't need motor self-learning as well if motor parameters are set accurately. If accurate motor parameters can't get on-site, or need to have more precise motor torque control by inverter, inverter can take one time of motor self-learning after elevator installed. Motor specific parameters, such as internal resistance, inductance can then be obtained accurately and automatically, it will help controlling elevator more smoothly, providing better comfort to passengers.

This inverter takes simple static self-learning method for asynchronous motor. It doesn't need to hoist the cars on-site. The method of operation is as follows:

- 1) All wiring related to inverter and encoder must be correctly connected;
- 2) Inverter power on, setting all parameters required in group P01;
- 3) Ensure contactor between inverter and motor closed, (Both contactors need to be closed if there are two) inverter and motor must be well connected;
- 4) In operator main screen, select "2 Motor tuning", press key "ENTER" into "Self-learning" screen;
- 5) In "Self-learning" screen, change the data on right of the equation "ATUN=0" from 0 to 6, and press "ENTER" again, motor self-learning starts.

Screen shows a countdown number from 9, 8, 7, 6, 5, 4, 3, 2, 1 to 0. Self-learning finishes once 0 is displayed.

7.6 Adjust elevator moving direction

The correct moving direction must be confirmed before elevator running in high speed. Three factors affect the moving direction: up, down moving signal cable connection that controller passes to inverter, U, V, W three phase power cable connection between inverter and traction motor, synchronous motor and encoder feedback signal phase A and B connection. Procedure to adjust:

- 1) If analog speed reference mode is selected, a maintenance speed must be set in elevator controller. The recommend maintenance speed should be around 0.2 m/s;
- 2) If multi-section speed reference mode is selected, one of the speed section parameters (P03.07 ~ P03.13) for maintenance running in inverter group parameter P03 must be set in advance. Its value converted to elevator speed should be around 0.2 m/s;
- 3) Moving elevator up or down in maintenance operation, and observing the running condition. The following flow chart provides the method of tuning elevator moving direction:

Moving elevator upwards in maintenance running, Fig. 7.4 shows the procedure for tuning direction when elevator moves up.

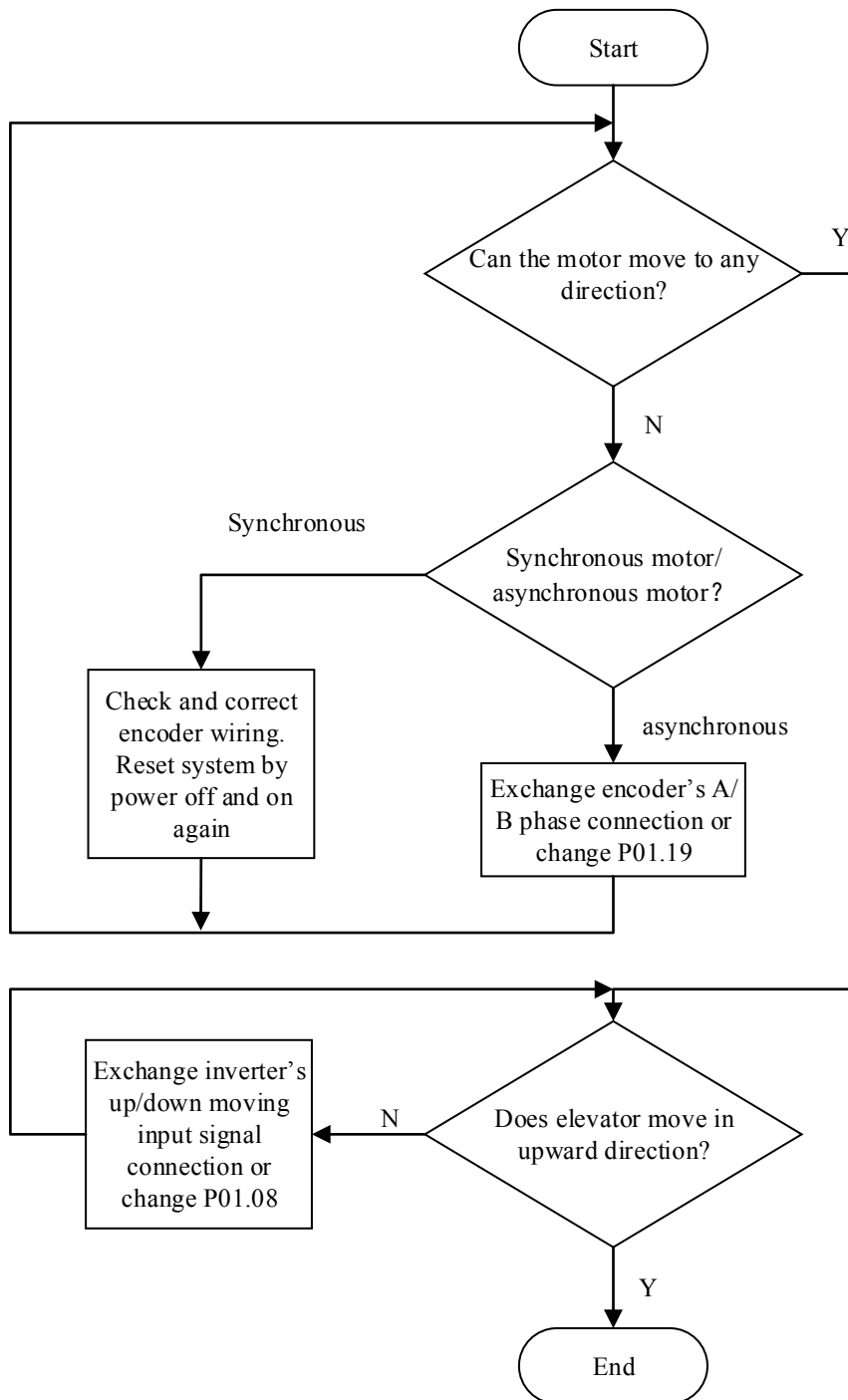

Fig. 7.4 Adjustment procedure in upward moving direction

4) Moving elevator downwards in maintenance running, Fig. 7.5 shows the procedure for tuning direction when elevator moves down.

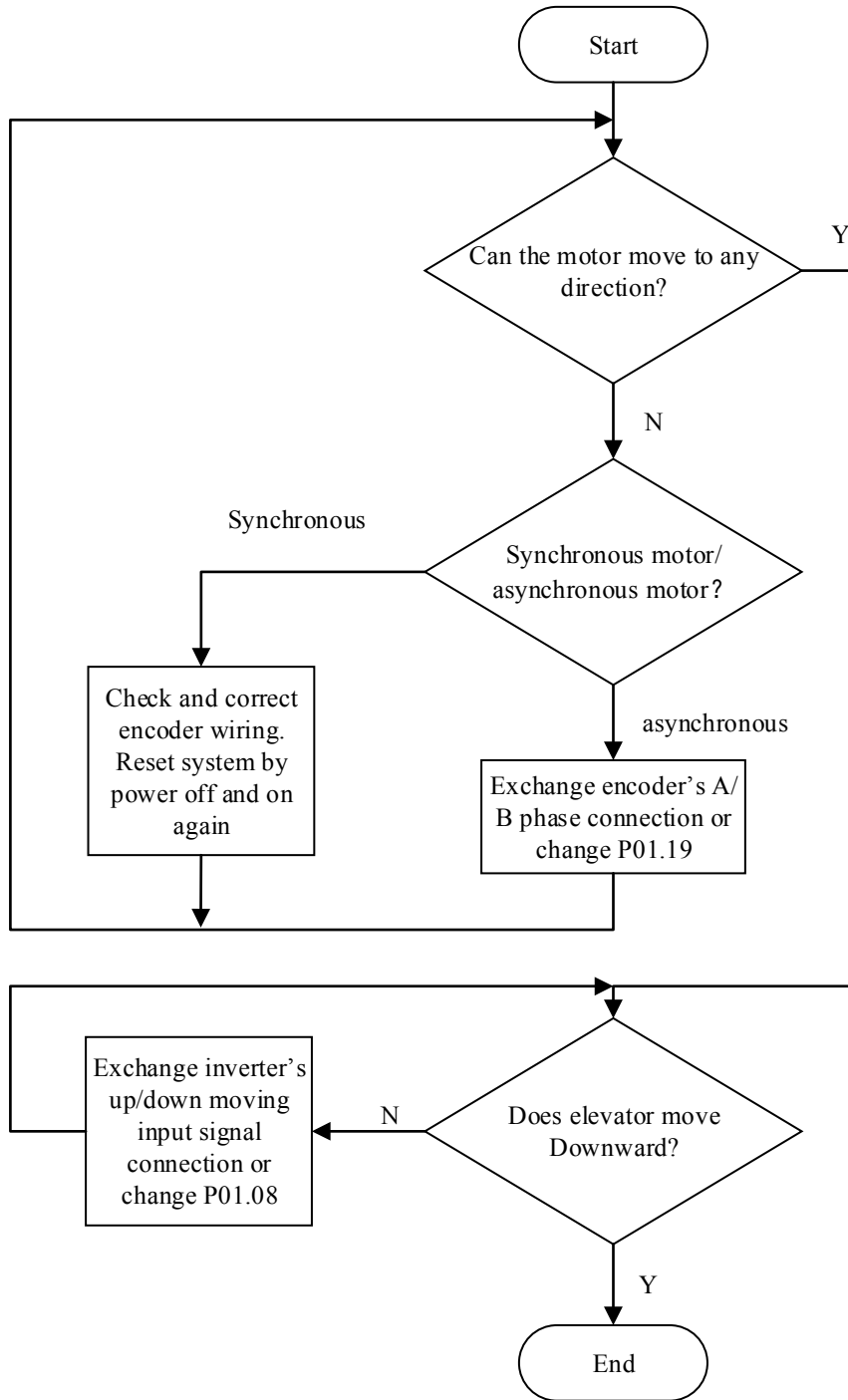

Fig. 7.4 Adjustment procedure in downward moving direction

7.7 Adjust speed curve

Tuning on elevator speed reference curve will affect the elevator efficiency and comfort directly. It is necessary to adjust the speed curve while elevator runs at high speed. For different speed reference modes, the way to tuning speed curve are also different. Following two sections will introduce them respectively.

7.7.1 Adjustment in analog speed reference mode

In analog speed reference mode, speed reference parameter P03.00 must conform to the following table.

Speed reference mode	P03.00 value
Analog speed reference input AI0	4

In analog speed reference mode, speed curve is provided by elevator controller. Therefore speed curve can only be tuned by modifying parameters of elevator controller. Parameters can be tuned in speed curve are: acceleration, deceleration, four S-shape curve rounds (acceleration value or S round time); round at starting, round at full speed, round at deceleration, and round at stopping. Increasing acceleration (deceleration) causes the curve steeper, reduces time of acceleration (deceleration), improves operation efficiency, but scarifies the comfort at the same time. Same for reducing transit time of S-shape curve round, it improves the operation efficiency and have negative impact on comfort. Tuning speed curve must reach the balance between the conflict of operation efficiency and comfortability. Rules to be followed are: 1. to meet the criteria of related national standard, for elevator speed 1 m/s and over, average acceleration or deceleration speed can't lower than 0.5 m/s. Considering the S round time, the parameters for acceleration (deceleration) speed usually aren't set lower than 0.6 m/s. 2. to tune speed curve based on passenger requirement, if most passengers focus on efficiency rather than comfort, parameter can be tuned in favor of efficiency improving. On the contrary, if more focus on comfort, parameters shall set in favor of comfortability.

7.7.2 Adjustment in multi-speed reference mode

In multi-section speed reference mode, speed reference parameter P03.00 must conform to the following table.

Speed reference mode	P03.00 value
Multi-section speed reference	1

In multi-section speed reference mode, elevator controller sends target speed reference value to inverter through digital signal. Normally the speed elevator taken multi-section speed reference mode isn't more than 2.5 m/s. Three digital input ports can meet the requirement. Three digital signal can create up to 8 states in binary code combination (include a zero speed), so controller can sent maximum eight speed commands to inverter. The actual speed command curve (S-shape curve) is calculated by inverter. That's way the acceleration time, deceleration time, and the time parameters for four S-shape curve rounds mentioned in previous section are all set in inverter. Value of all speed sections need also be set in inverter. The following table shows the parameter range of those setting and adjustment.

Function code	Name	Content	Setting range	Unit	Factory default	Remarks
P03.00	Speed reference mode	0: panel setting 1: Digital multi-section speed reference 4: Analog speed reference AI0 6: Analog speed reference AI1	0/1/4/6	×	4	Invalid when P00.02 is 2
P03.01	Acceleration time	Elevator acceleration slope (the constant acceleration) is decided by this parameter. It's an accelerating time from 0 to maximum speed in constant acceleration style. Please note this is not the same as average acceleration. Average acceleration relates also the value of two acceleration rounds beside this value.	0.1~60.0	s	2.5	Only valid in multi-section speed reference
P03.02	Deceleration time	Elevator deceleration slope (the constant deceleration) is decided by this parameter. It's a decelerating time from maximum speed to 0 in constant deceleration style. Please note this is not the same as average deceleration. Average deceleration relates also the value of two deceleration rounds beside this value	0.1~60.0	s	2.5	Only valid in multi-section speed reference
P03.03	Acceleration round time 0	Set time for acceleration round at starting in S-shape curve. The longer the time, the smaller the jerk value is; otherwise the jerk value is bigger.	0.0~10.0	s	1.3	Only valid in multi-section speed reference
P03.04	Acceleration round time 1	Set time for acceleration round at constant speed section in S-shape curve. The longer the time, the smaller the jerk value is; otherwise the jerk value is bigger	0.0~10.0	s	1.3	Only valid in multi-section speed reference
P03.05	Deceleration round time 0	Set time for deceleration round at starting of speed reduction in S-shape curve. The longer the time, the smaller the negative jerk value is; otherwise the negative jerk	0.0~10.0	s	1.3	Only valid in multi-section speed reference

Function code	Name	Content	Setting range	Unit	Factory default	Remarks
		value is bigger.				
P03.06	Deceleration round time 1	Set time for deceleration round at ending of speed reduction in S-shape curve. The longer the time, the smaller the negative jerk value is; otherwise the negative jerk value is bigger	0.0~10.0	s	1.3	Only valid in multi-section speed reference
P03.07	Speed reference 1	Set digital multi-section speed reference 1, Unit is in Hz	0.0~60.0	Hz	2.5	Only valid in multi-section speed reference
P03.08	Speed reference 2	Set digital multi-section speed reference 2, Unit is in Hz	0.0~60.0	Hz	1.2	Only valid in multi-section speed reference
P03.09	Speed reference 3	Set digital multi-section speed reference 3, Unit is in Hz	0.0~60.0	Hz	1.5	Only valid in multi-section speed reference
P03.10	Speed reference 4	Set digital multi-section speed reference 4, Unit is in Hz	0.0~60.0	Hz	5.0	Only valid in multi-section speed reference
P03.11	Speed reference 5	Set digital multi-section speed reference 5, Unit is in Hz	0.0~60.0	Hz	25.0	Only valid in multi-section speed reference
P03.12	Speed reference 6	Set digital multi-section speed reference 6, Unit is in Hz	0.0~60.0	Hz	40.0	Only valid in multi-section speed reference
P03.13	Speed reference 7	Set digital multi-section speed reference 7, Unit is in Hz	0.0~60.0	Hz	50.0	Only valid in multi-section speed reference

Note 1: Multi-section speed reference setting

- 1) First of all, ensure P03.00 is set to 1 (digital multi-section speed reference mode is selected)
- 2) Because rated speed of most elevators don't exceed 2.5 m/s, and it is also not recommended to use digital multi-section speed reference mode if rated speed is over 2.5 m/s, we will only introduce multi-section speed reference mode with three digital inputs. Three digital signals can form to eight multi-section speed commands (includes a zero speed). P03.07 ~ P03.13 are corresponding to seven non-zero parameters. (Speed reference 1 ~ speed reference 7) These are speed section values for the seven speed references. Each speed is a speed command in different elevator operation stages. In normal elevator operation (rated speed is lower than 2.5 m/s), following speed sections are required.

Speed section name	Description
Maintenance speed	Running speed in maintenance, automatic leveling
Re-leveling speed	Speed at re-leveling after door open
Half maintenance speed	Running speed at terminal floor (terminal deceleration switch triggered) in operation of maintenance or automatic leveling
High speed 1 (single floor speed)	Speed for one floor running during automatic high speed operation; it's also the speed for double and multi floor if elevator speed is not faster than 1 m/s
High speed 2 (double floor speed)	Speed for double floor running during automatic high speed operation; it's also the speed for multi floor if elevator speed is not faster than 1.75 m/s. This speed section is not required if elevator speed isn't faster than 1 m/s
High speed 3 (multi floor speed)	Speed for three or more floors running during automatic high speed operation; it can also be the elevator rated speed. This speed section is not required if elevator speed isn't faster than 1.75 m/s
Leveling speed (creep speed)	Speed of last distance during deceleration, or in automatic leveling period. Speed within door area

In order to set section speed parameter correctly, it should be cleared that how elevator controller defines the speed reference code. That means to match each section speed in above table, the status for three digital outputs as speed reference signal should be clearly defined. The following example shows how to set section speed parameter through elevator controller.

Next table shows the speed reference code from elevator controller and their section name:

Speed reference code	Speed section name
1	Maintenance half speed
2	Re-leveling speed
3	Leveling speed (Creep speed)
4	Maintenance speed
5	High speed 1 (single floor speed)
6	High speed 2 (double floor speed)
7	High speed 3 (multi floor speed)

The speed reference codes in above table are combined by three digital inputs in different status. Details please refer to chapter 6, section 6.2.4, table 6.2. The parameter setting for section speed can be set as following table if elevator rated speed is 2 m/s.

Parameter	Speed section name	Value
Non	Zero speed	0
P03.07 (speed reference 1)	Maintenance half speed	3Hz (elevator speed 0.12m/s)
P03.08 (speed reference 2)	Re-leveling speed	0.75 Hz(0.03m/s)
P03.09 (speed reference 3)	Leveling speed (Creep speed)	1.25 Hz(0.05m/s)
P03.10 (speed reference 4)	Maintenance speed	6 Hz(0.24 m/s)
P03.11 (speed reference 5)	High speed 1 (single floor speed)	25 Hz(1 m/s)
P03.12 (speed reference 6)	High speed 2 (double floor speed)	40 Hz(1.6 m/s)
P03.13 (speed reference 7)	High speed 3 (multi floor speed)	50 Hz(2 m/s)

In actual installation, user can modify it if speed reference code of controller isn't the same as above case, as long as user understands the example.

Note 2: Tuning parameters for acceleration (deceleration) time and S-shape curve round

P03.01 and P03.02 are tuning parameters for elevator acceleration time and deceleration time. P03.03 ~ P03.06 are tuning parameters for four rounds of S-shape curve. The function and tuning method of these parameters are similar to the analog speed reference which has been introduced. The difference is: these parameters are tuned in elevator controller in analog speed reference mode, they are tuned in inverter in multi-section speed reference. It should also be specified that parameters P03.03 ~ P03.06 are each S-shape curve round transit time. The smaller the parameter value is, the higher the round jerk acceleration is, and also the higher efficiency the elevator can be. But it will affect the comfortability. On the contrary, the big value reduces the round jerk acceleration, lower the efficiency, but provides better comfort.

For your tuning reference, following Fig. 7.6 provides the positions of parameters of P03.01, P03.02, P03.03 ~ P03.06 in moving speed curve.

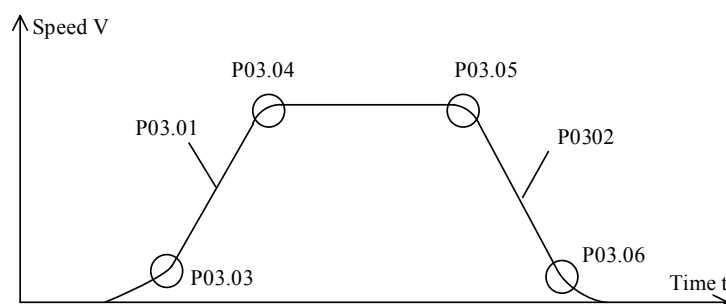

Fig. 7.6 Position of each parameters in tuning speed curve

7.8 Comfortability tuning

Riding comfort is an important criteria to evaluate the elevator performance. Many factors can affect the comfort, from mechanical perspective, those factors can be rail and guide shoe installation and adjustment, the performance of traction machine, etc. The factors in electric can be the

performance of speed curve, the degree of analog speed reference signal interfered by electromagnetic (if analog speed reference mode is selected), quality of encoder feedback signal and inverter driving performance. As an inverter instruction manual, the following discuss in this manual is based on that all above factors related to comfort have been properly adjusted. We will discuss how to tune parameters of inverter and improve the inverter performance, in order to reach the better riding comfort.

7.8.1 Comfort tuning at start

This inverter has a unique technology of starting compensation without loading sensor. That means an excellent starting comfort can be achieved by tuning parameters even without pre-load device for starting compensation.

7.8.1.1 Regular starting comfort tuning method

Generally, tuning inverter zero servo parameters PID and excitation time can improve the elevator starting comfort effectively. To tune related parameters refers to the table below.

Function code	Name	Content	Setting range	Unit	Factory default	Remarks
P02.00	Zero servo gain P0	PID regulator gain value when zero servo is active	0.00~ 655.35	×	130.00	
P02.01	Zero servo integral I0	PID regulator integral value when zero servo is active			80.00	
P02.02	Zero servo differential D0	PID regulator differential value when zero servo is active			0.50	
P02.14	Excitation time	Inverter receives run command, after this time of excitation, run signal is sent and elevator brake can be released.	0.0~ 10.0	s	0.3	Only for asynchronous motor
P02.15	Zero servo time	This is a torque holding time from operation signal sent by inverter to starting acceleration	0.0~ 30.0	s	0.5	

Note 1: About excitation time

If the traction drive is an asynchronous motor, a certain excitation time is required before torque is output. A high power motor needs more excitation time. P02.14 is a parameter for tuning excitation time. Too small P02.14 value can't output enough torque before elevator brake released, it will affect the comfort. But the large P02.14 value will cause other improper situations such as slow starting.

Note 2: Tuning speed loop PID regulator at starting point

P02.15 is the time parameter for zero servo. It tunes the delay time for adjusting system speed reference curve. This is also the acting time of PID regulator P0, I0 and D0 at zero servo (zero

speed). Detail acting sequences see the following chart.

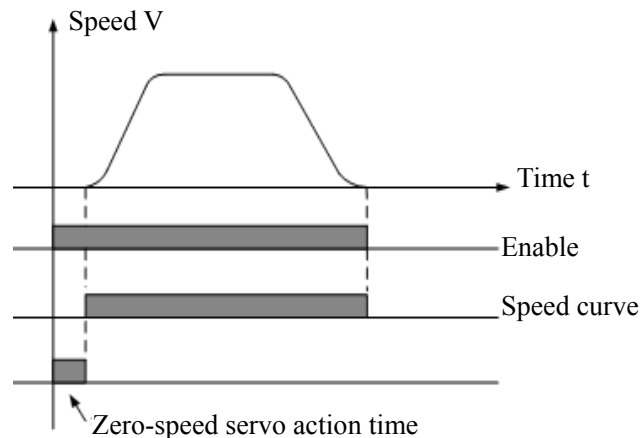

Fig. 7.7 Zero servo time sequence

Please note that in multi-section speed reference mode, speed curve is generated by inverter itself. Therefore it is naturally supplied after end of zero servo time. If analog speed reference mode is taken, speed curve is provided by controller, it is independent from inverter. Therefore the time that control system supplies for the speed reference curve must match the inverter zero servo time. If the speed curve provided by control system is earlier than end of zero servo time, inverter will not take any speed reference during the zero servo time, the speed curve is invalid in this case. The actual speed curve might cause abrupt change and affects the elevator starting comfort. If the speed curve provided by control system is later than end of zero servo time, inverter will keep speed reference value 0, maintains torque (still in zero servo status) after end of set zero servo time. In this case, the end of actual zero servo time should be extended to the actual starting of speed reference.

P02.00, P02.01 and P02.02 are gain (P0), constant integral (I0) and constant differential (D0) of zero servo regulator. During tuning, set a very small value for P0, move elevator downward with no load, elevator feels reverse pull back at starting. To increase P0 value gradually till the reverse pull isn't felt. Too large P0 value can cause elevator vertical vibration at starting. P0 value needs to be tuned smaller if the vertical vibration is serious. I0 is PID regulator constant integral at zero speed starting. The bigger the I0 value is, the faster the response time is. If I0 is too small, P0 can't act in time. If I0 is too big, it can cause high frequency oscillation easily. D0 helps the system responding time. The bigger the D0 value is, the faster the response time is. But too big D0 can also cause oscillation.

7.8.1.2 Improving elevator starting comfort by tuning time sequence

Starting sequence means the sequence of following steps when elevator receives run command. There are: closing main contactor, sending inverter upward/downward command (or enable signal), releasing brake, and speed reference signal. Normal steps for starting elevator are: closing main contactor, giving inverter enable signal, then commands for releasing brake and speed reference. The sequence of speed reference and braking will affect starting comfort greatly. The ideal coordination is that the brake mechanism action (real release) can happen with the output of speed reference simultaneously. Due to the brake contactor delay time and brake mechanism delay time, it is not easy to provide an accurate time and reaches an ideal action requirement. Following rules can be used to

adjust the time sequence: in elevator no-load operation, tuning to delay brake releasing time (or sending speed reference earlier) when a clear reverse pull is felt in down collective moving; tuning brake releasing time earlier (or delay the speed reference time) if reverse pull isn't felt in down collective moving, but elevator runs too rush in up collective moving. Start and end sequence can refer to the following Fig. 7.8.

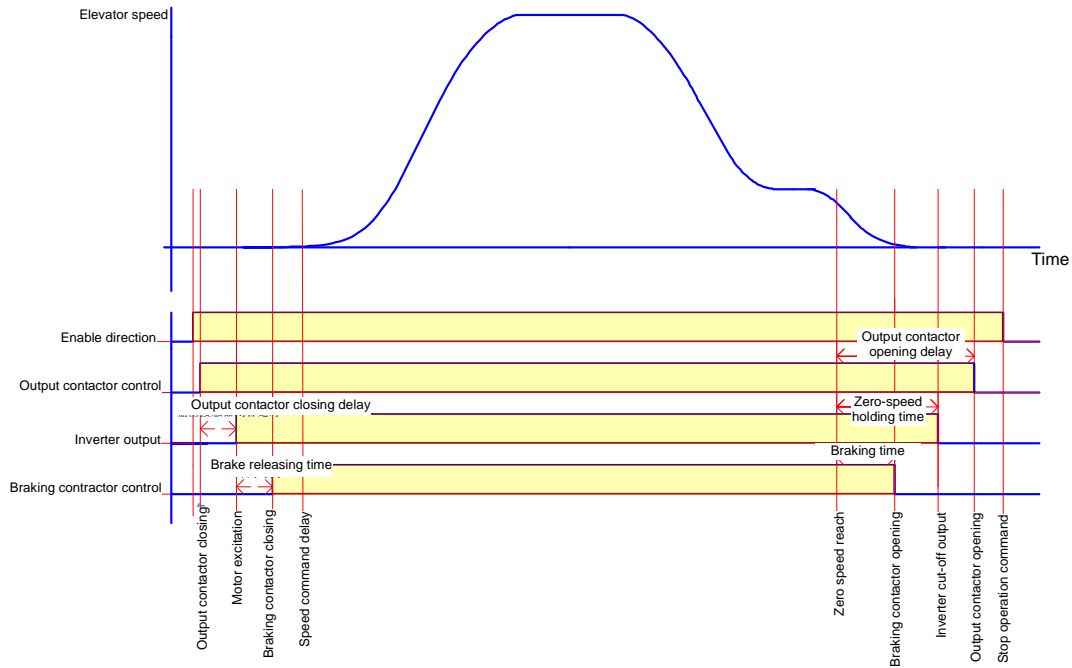

Fig. 7.8 The adjustable time sequence chart

7.8.2 Comfort tuning during moving

Improving elevator moving comfort can be achieved by tuning parameters of PID regulator in each speed section. Following table lists the parameters can be tuned:

Function code	Name	Content	Setting range	Unit	Factory default	Remarks
P02.03	Low speed section gain P1	PID regulator gain value activated when speed reference is lower than switch frequency F0			70.00	See explanation below
P02.04	Low speed section integral I1	PID regulator integral value activated when speed reference is lower than switch frequency F0			30.00	See explanation below
P02.05	Low speed section differential D1	PID regulator differential value activated when speed reference is lower than switch frequency F0			0.50	See explanation below

Function code	Name	Content	Setting range	Unit	Factory default	Remarks
P02.06	Moderate speed section gain P2	PID regulator gain value activated when speed reference is between switch frequency F0 and F1			120.00	
P02.07	Moderate speed section integral I2	PID regulator integral value activated when speed reference is between switch frequency F0 and F1			25.00	
P02.08	Moderate speed section differential D2	PID regulator differential value activated when speed reference is between switch frequency F0 and F1			0.20	
P02.09	High speed section gain P3	PID regulator gain value activated when speed reference is greater than switch frequency F1			140.00	
P02.10	High speed section integral I3	PID regulator integral value activated when speed reference is greater than switch frequency F1			5.00	
P02.11	High speed section differential D3	PID regulator differential value activated when speed reference is greater than switch frequency F1			0.10	
P02.12	Low speed switch frequency F0	Set switch frequency parameter at PID regulator low speed section. It is set as a percentage of rated frequency. For example: rated frequency is 50 Hz, needed switch frequency F0 is 10 Hz, 10 is 20% of 50, the parameter should be set to 20	0.~ 100.0	%	1.0	See explanation below In moderate speed section between F0 and F1, PID value is automatically calculated based on low and high speed PID value
P02.13	High speed switch frequency F1	Set switch frequency parameter at PID regulator high speed section. It is set as a percentage of rated frequency. For example: rated frequency is 50 Hz, needed switch frequency F1 is 40 Hz, 40 is 80% of 50, the parameter should be set to 80	0.0~ 100.0	%	50.0	See explanation below In moderate speed section between F0 and F1, PID value is automatically calculated based on low and high speed PID value

Parameters P02.03 ~P02.05 are low speed section PID regulator P, I and D value (P1, I1, D1). P02.06 ~P02.08 are moderate speed section PID regulator P, I and D value (P2, I2, D2). P02.09 ~P02.11 are high speed section PID regulator P, I and D value (P3, I3, D3). They are applied in all elevator operation period and each section of running curve (refer to Fig. 7.9). Parameters P02.12 and P02.13 are switch frequency for dividing section (refer to Fig. 7.9). The riding comfort in each

section can be improved by tuning those parameters from P02.03 ~P02.05, P02.06 ~P02.08, P02.09 ~P02.11, P02.12 and P02.13

Increasing proportion constant P can enhance the capability of dynamic responding, but it may cause overshooting and oscillation if P value is too big. Following chart shows the relationship of P to feedback track.

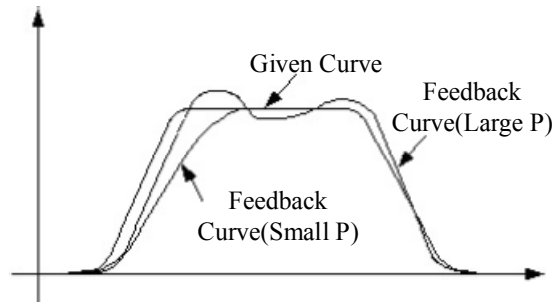

Proportion constant P affects feedback track

Increasing integral constant I speeds up the dynamic responding time, I can be increased appropriately if system overshoot is too big or dynamic responding is too slow. But it may cause oscillation if I value is too big. Following chart shows the relationship of integral constant to feedback speed.

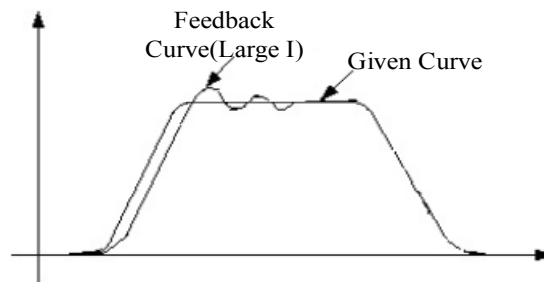

Proportion integral I affects feedback track

Likewise, increasing differential constant D improves the system sensitivity, but it may cause oscillation if D value is too big.

In PID regulator parameter tuning, proportion constant P is normally set at first. P value needs to be increased as much as possible while keeping system in no oscillation, then tuning integral constant I and achieves a quick response, low overshoot. Value D needs only be tuned when tuning of P and I can't be satisfied.

Section of PID regulator in elevator operation curve is shown in Fig. 7.9.

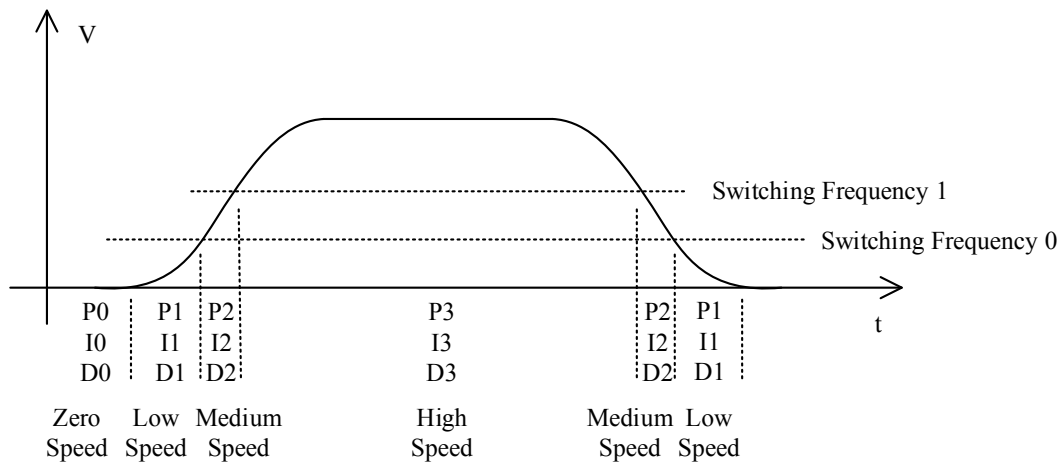

Fig. 7.9 Elevator operation curve sectional PI control

From above chart we can see that tuning of inverter PID regulator has three separate speed sections. It greatly simplifies the system adjustment. If the comfort in high speed is an issue, only PID parameters in high speed section need to be tuned. It wouldn't affect the other two sections. Same for other two speed sections, only the PID parameters in comfort related speed section need to be modified. To obtain the best comfort, PID parameters in different speed sections are not same. By tuning PID individually makes all speed sections reaching their perfect comfort.

7.8.3 Comfort tuning at stop

Two factors affects the riding comfort when elevator stopping: first, PID value in low speed section. Based on the introduction in previous section, tuning PID in low speed section and reaches the best comfort at stopping. Second, the stopping time sequence, it is the sequence of speed reference and braking action. The ideal status is that elevator brake just activates while speed reference goes down to zero. The principle of tuning: if elevator has rush stop while stopping, it means the brake action starts too early; if elevator has sliding while stopping, it means the brake action starts too late.

7.9 Additional function description

Previous sections in this chapter introduced the inverter tuning methods in regular elevator adjustment. This section will introduce some new functions and how they are used. Please refer to it when it is required.

7.9.1 Introduction – preload weighing compensation method

through analog input

This inverter has a new technology of starting compensation with no-load sensor. Elevator doesn't need to install pre-load weighing device. A very good starting comfort can be obtained by

using this technology of starting compensation with no-load sensor. Its starting characteristic shows in Fig. 7.10.

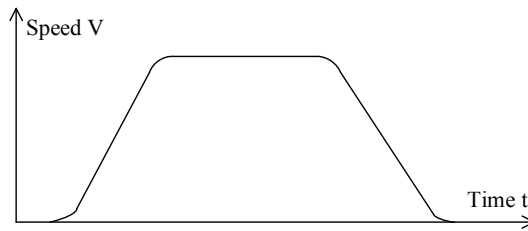

Fig. 7.10 Chart for starting compensation with no-load sensor

Normally AS320 series inverter doesn't need pre-load weighing device. In some places analog weighing device has been installed in order to get the over or full load signal; or this pre-load weighing device for starting compensation is specifically required due to the high demand for starting comfort. The other case that needs to have pre-load weighing device is that a gearless traction machine is used and its encoder doesn't meet the requirement for no-load starting compensation. Starting torque compensation method is used by inverter in this case. When pre-load starting compensation is taken, weighing device is required to output analog DC voltage signal, and analog signal should have good linear characteristic. Analog voltage signal of weighing device is connected to analog input port A1 in inverter. Fig. 7.11 shows the wiring diagram.

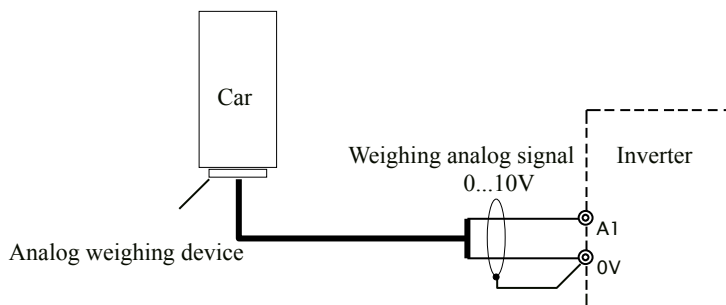

Fig. 7.11 Weighing analog signal wiring diagram

When pre-load weighing device for starting compensation is used, parameters need to be set and adjusted are listed in following table.

Function code	Name	Content	Setting range	Unit	Factory default	Remarks
P04.01	Torque compensation reference mode	0: No torque compensation 1: Compensation based on light/heavy load switch 2: AI0 analog torque reference 3: AI1 analog torque reference	0/1/2/3	×	0	
P04.02	Direction of torque compensation	0: Positive direction 1: Opposite direction	0/1	×	0	
P04.03	Torque compensation gain	Set torque compensation gain	0.0~200.0	%	100.0	Only valid when P04.01 is set to 2~3
P04.04	Torque compensation offset	Set torque compensation offset	0.0~100.0	%	0.0	Only valid when P04.01 is set to 2~3
P07.07	Function of AI1 analog input	Set analog input port AI0~AI1, each function of parameter is: 0: Invalid (no use) 2: Analog speed reference 3: Analog torque reference 4: Analog compensation torque reference	0/2/3/4	×	0	If necessary, AI1 analog input can be set to analog torque compensation input
P07.08	AI1 analog input offset	Set offset voltage for AI1 analog input	0.000~20.000	V	10.000	
P07.09	AI1 analog input gain	Set gain value for AI1 analog input, it is a percentage data	0.0~100.0	%	100.0	
P07.10	AI1 analog input filtering time	Set filtering time for AI1 analog input signal	0~30	ms	10	

Note 1: Mandatory parameter setting for analog pre-load weighing compensation mode

First set P04.01 to 3, torque reference compensation is defined to AI1 analog input torque compensation type. And P07.07 should be changed as well and set to 4, designate analog input AI1 as the analog signal input port for pre-load torque compensation.

Note 2: Utilizing tuning parameters

P04.02 is a parameter for pre-load compensation direction. For some reason that the system torque compensation direction is reversed, to change P04.02 parameter from 0 to 1 can easily solve the problem. Here is the way to judge the correction of torque compensation direction: in light load condition, the compensation direction is correct if increasing value of P04.03 will cause reducing upward impact, or increasing downward impact while elevator starting. Otherwise if increasing value causes reducing downward impact or increasing upward impact while starting, the direction is

wrong. P04.02 can be modified and direction is reversed. Same for heavy load condition, the compensation direction is correct if increasing value of P04.03 will cause reducing downward impact, or increasing upward impact while elevator starting. Otherwise if increasing value causes reducing upward impact or increasing downward impact while starting, the direction is wrong. P04.02 can be modified and direction is reversed.

P07.08 is a parameter for AI1 analog input, pre-load torque compensation offset. If AI1 analog voltage signal output is not 0 while load is balanced, parameter P07.08 needs to be set. Otherwise the factory default value 10.00 should be used.

Formula for set of P07.08 is: $P07.08 = 10.000 - \text{actual zero offset of AI1 analog input (AI1 analog voltage input signal while load balance)}$

For example: the zero offset of AI1 analog voltage input is 0.100V, then

$$P07.08 = 10.000 - 0.100 = 9.900$$

This method can be used in real tuning: in elevator balance loading, set maintenance speed to 0, P07.08 is tuned to a still position during in elevator maintenance running.

P07.09 is a parameter for AI1 analog input, pre-load torque compensation gain. After finishing parameter P04.02 tuning (pre-load compensation direction), P07.09 can be tuned like this: tuning up this parameter value, compensation amount is increased under same analog input value, tuning down will reduce the compensation amount. Therefore if downward impact (slip by upward, rush by downward) happens at heavy load starting, upward impact (slip by downward, rush by upward) happens at light load starting, that means the compensation is not enough and needs to tune up gain parameter P07.09. On the contrary, if upward impact (slip by downward, rush by upward) happens at heavy load starting, downward impact (slip by upward, rush by downward) happens at light load starting, that means the compensation is too much and needs to tune down gain parameter P07.09.

P04.03 is parameter for torque compensation gain. It has the same function as P07.09 in tuning of pre-load torque compensation. Improving pre-load torque compensation mentioned in last paragraph by setting P07.09 can also be done through tuning P04.03. Same for P04.04, a parameter for torque compensation offset, it has the same function as P07.07 in tuning of pre-load start torque compensation. Detail description of P04.03 and P04.04 can refer to section 6.2.5.

P07.10 is a parameter for filtering time of AI1 analog input. It is set to 10 (default) in normal situation. If the site has strong interference and can't be solved by hardware processing, a small amount of filtering time can be added to improve the anti-interference capability of analog input signal. But filtering time can be too long, or the response capability and result of pre-load start compensation will be affected.

7.9.2 Starting compensation method by using light/heavy duty switch

AS320 elevator inverter has beside the mode of analog input pre-load start compensation, also a simply compensation mode: light/heavy load switch compensation. Taking this compensation mode, encoder can use 8192 pulse ABZ incremental type, no extra precise weighing device is required, and only two micro-switches are installed at bottom. If no-load weighing compensation start is taken for elevator using synchronous gearless traction machine, a higher resolution SIN/COS encoder must be installed. Comparing to ABZ incremental encoder, SIN/COS encoder is more expensive, more

wiring and weak anti-interference. Light/heavy load switch start compensation mode has the advantage of low cost, less wiring and strong anti-interference capability. Comparing to analog input pre-load start compensation mode, light/heavy load switch compensation mode has the advantage of low cost, easy installation and simply adjustment due to the saving of a precise weighing device. From this point of view, we recommend our AS320 elevator inverter clients using this light/heavy load switch compensation mode.

To use light/heavy load switch start compensation mode, one light load switch, one heavy load switch need to be installed at the bottom of car frame. Light load switch is triggered by car load is less than 25% of rated load. Heavy switch is triggered by car load is more than 75% of rated load. Input signal from both switches must be connected to the corresponding X input in inverter.

Parameters needed for light/heavy load switch start compensation mode are listed in following table.

Function code	Name	Content	Setting range	Unit	Factory default	Remarks
P04.01	Torque compensation reference mode	0: No torque compensation 1: Compensation based on light/heavy load switch 2: AI0 analog torque reference 3: AI1 analog torque reference	0/1/2/3	×	0	
P04.02	Direction of torque compensation	0: Positive direction 1: Opposite direction	0/1	×	0	
P04.05	Light load switch compensation	Set compensation of downward torque when light load switch triggered	0.0~ 100.0	%	0.0	Only valid when P04.01 is set to 1
P04.06	Heavy load switch compensation	Set compensation of upward torque when heavy load switch triggered	0.0~ 100.0	%	0.0	Only valid when P04.01 is set to 1
P05.00	Definition of X0 input terminal function	Sex X0 input, details refer to section 6.2.6		×	0	Recommend : P05.00 = 19, X0 is light switch input
P05.01	Definition of X1 input terminal function	Sex X1 input, details refer to section 6.2.6		×	0	Recommend : P05.00 = 20, X0 is heavy switch input

Note 1: Mandatory parameter setting for light/heavy load weighing compensation mode

First set P04.01 to 1, torque reference compensation is set to light/heavy load switch signal input torque compensation type. And P05.00 should be set to 19, X0 is defined to light load switch input; P05.01 should be set to 20, X1 is defined to heavy load switch input (note 3 will specify the selection of light/heavy load switch further).

Note 2: Utilizing tuning parameters

P04.02 is a parameter for pre-load compensation direction. For some reason that the system torque compensation direction is reversed, to change P04.02 parameter from 0 to 1 can easily solve the problem. Here is the way to judge the correction of torque compensation direction: in light load

condition (light load switch triggered), the compensation direction is correct if increasing value of P04.05 will cause reducing upward impact, or increasing downward impact while elevator starting. Otherwise if increasing value causes reducing downward impact or increasing upward impact while starting, the direction is wrong. P04.02 can be modified and direction is reversed. Same for heavy load condition (heavy load switch triggered), the compensation direction is correct if increasing value of P04.06 will cause reducing downward impact, or increasing upward impact while elevator starting. Otherwise if increasing value causes reducing upward impact or increasing downward impact while starting, the direction is wrong. P04.02 can be modified and direction is reversed.

P04.05 and P04.06 are two tuning parameters for simply light/heavy load switch torque compensation. Both switches are connected to inverter digital input (X0 and X1). P04.05 is a tuning parameter for simply light load torque compensation when light load switch triggered. If upward impact (slip back by downward, rush by upward) happens at light load starting, that means the light load compensation is not enough and needs to tune up the value of P04.05. On the contrary, if downward impact (slip back by upward, rush by downward) happens at light load starting, that means the light load compensation is too much and needs to tune down the value of P04.05. Same for heavy load condition, P04.06 is a tuning parameter for simply heavy load torque compensation when heavy load switch triggered. If downward impact (slip back by upward, rush by downward) happens at heavy load starting, that means the heavy load compensation is not enough and needs to tune up the value of P04.06. On the contrary, if upward impact (slip back by downward, rush by upward) happens at heavy load starting, that means the heavy load compensation is too much and needs to tune down the value of P04.06.

Note 3: Select light/heavy load switch input

Based on the specific feature for elevator operation, we recommended X0 for light load switch signal input (set P05.00 to 19), X1 for heavy load switch signal input (set P05.00 to 20), in previous note 1. User can also define other input ports as light/heavy load switch signal input other than X0 and X1 as per actual need. In this inverter, three input ports X2 ~ X4 can be redefined if analog voltage signal input for speed reference is selected. X5 can be redefined its input function if inverter base block signal isn't used. Beside X0 and X1, two of four ports from X2 ~ X5 can be selected for light/heavy load switch signal input if above mentioned condition is met. At that time, one input parameter should be set to 19 (light load switch input), other input parameter is set to 20 (heavy load switch input), according the function definition in previous table.

7.9.3 Bus low voltage operation mode for emergent leveling

In case of emergent power off during elevator running, elevator may be stuck in the hoistway well. Enclosed passengers are trapped in the car until help person are informed and go to the site, then the car be slowly lowed by using hand-barring. This way will cause lot trouble for passengers. So a power off emergent leveling device is added in most elevators. Since a fully independent emergent leveling device is costly, to add an inverter function of low voltage, low speed operation (Only batteries provide power by power off, normally four batteries in total of 48V, or 220V UPS supply are used.), plus some special handling in controller, a simple emergent leveling device is built up. This solution can release passengers automatically during power off, and also relatively save the cost.

During bus cable low voltage operation, a digital input port must be defined as emergent power supply (Bus low voltage operation) signal input. Parameters in following table need to be set.

Function code	Name	Content	Setting range	Unit	Factory default	Remarks
P05.00	Definition of X0 input terminal function	Set X0 input function. Refer to section 6.2.6 for details		×	0	
P05.01	Definition of X1 input terminal function	Set X1 input function. Refer to section 6.2.6 for details		×	0	
P05.02	Definition of X2 input terminal function	Set X2 input function. Refer to section 6.2.6 for details		×	3	
P05.03	Definition of X3 input terminal function	Set X3 input function. Refer to section 6.2.6 for details		×	4	
P05.04	Definition of X4 input terminal function	Set 4 input function. Refer to section 6.2.6 for details		×	5	
P05.05	Definition of X5 input terminal function	Set X5 input function. Refer to section 6.2.6 for details		×	18	Recommend : P05.05 = 16, X5 is low voltage operation input

Actually only one parameter in above table, to select an input as low voltage operation signal input, needs to be set. We recommend to set P05.05 to 16. X5 is then defined as input port for emergent power operation signal (Assume that base block signal is not used). When X5 is connected, inverter enters into bus low voltage operation mode. Inverter can operate under bus cable voltage of 48V in low speed. There are two types of bus low voltage operation modes, the first mode uses batteries as power supply, UPS as inverter controlling supply. Fig. 7.10 shows the basic circuit diagram of this main loop. The batteries are 48V (four 12V batteries in series), not less than 20Ah. Please note: this type must add emergency power.

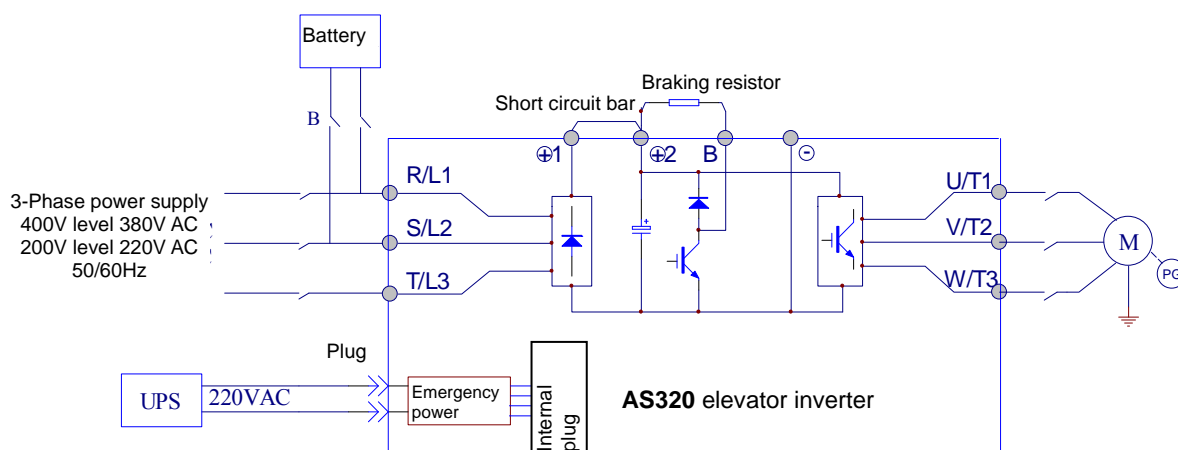

Fig. 7.12 Basic circuit diagram for bus low voltage operation powered by UPS and battery

The second mode uses UPS as power supply for both power and control. No battery is needed. The basic circuit diagram of main loop shows in Fig. 7.13.

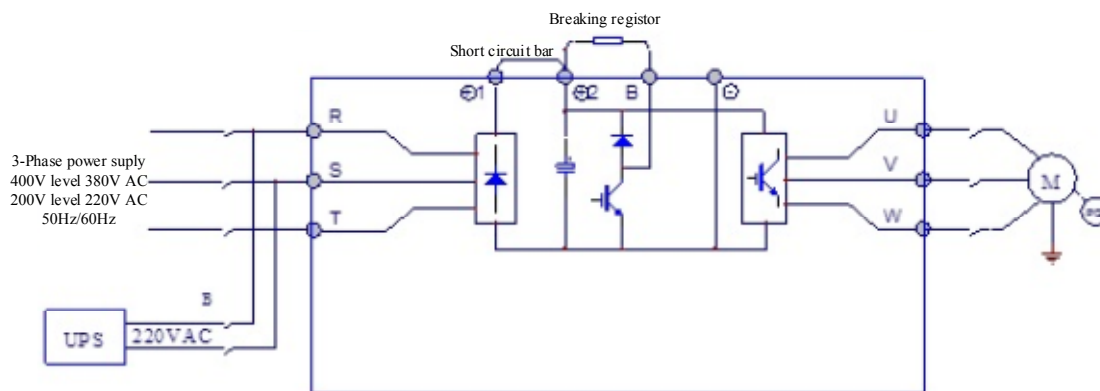

Fig. 7.13 Basic circuit diagram for bus low voltage operation powered by UPS only

Please note that B contactor in last diagram can only be closed in emergent power off.

Otherwise different power supply can cause conflict and creates series fault.

When power off and bus low voltage operation is operated for emergency leveling, UPS and battery (if battery is used simultaneously) all provide power to inverter and controller. Elevator controller has a special contactor inspection for emergent power off. Controller sends a signal to X5 (this port is set for emergency power signal) input port of inverter once emergent power off is detected, and tells inverter the status of emergency leveling. Inverter then allows bus low voltage operation. Elevator runs in one direction to the nearest level and stop in low speed. Emergency leveling operation finishes after door opened.

7.9.4 Wiring and parameter setting method for a single contactor in main circuit

According to national elevator safety standard GB-7588, main circuit must conform to one of following two conditions:

1) Having two independent contactors, each one can cut off traction motor loop. If main contact of a contactor doesn't open, car must be prevented to running latest to the next moving direction change. Or:

2) Having one contactor for cutting off traction motor loop, also having a controlling device for block current flow in static component. Plus a monitoring device to check the current flow or block at each stop. The regulation is: during normal stop, if static component can't block the current flow, monitoring device should control contactor releasing and prevent elevator operating again.

If inverter can't accurately provide current block signal in time while elevator stops, elevator control system doesn't have the ability to use monitoring device in above (b) condition. The main loop must use two contactors. AS320 series inverter can detect whether current flow or block accurately while elevator stops, and output result in time. Once the elevator controller and AS320 series inverter are correct combined, control system has a monitoring device and can conform (b) condition. Only one contactor is used in main loop. It reduces component and cost as well.

Therefore a parameter needs be set to define an above mentioned current detect signal as digital output port. A threshold value for zero current detect is also need to set. Related parameters are shown below.

Function code	Name	Content	Setting range	Unit	Factory default	Remarks
P06.18	Non zero current detect threshold at stopping	When stopping, inverter has current and it is greater than this set value, non zero current detection signal is valid. It is a percentage data. The actual value is this data times rated current and divided by 100	0.0~100.0	%	2.0	P06.18
P06.00	Output function definition K1 Port	Set K1 input function. Refer to section 6.2.7 for details		×	0	Recommend : P06.00 = 15, K1 is non-zero current detection output signal
P06.01	Output function definition K2 Port	Set K2 input function. Refer to section 6.2.7 for details		×	0	

We recommend to set P06.00 to 15. K1 (relay) output is then defined as non-zero current detect signal output. K2 can also be defined as non-zero current detect signal output (set P06.01 to 15). Parameter P06.18 (Non-zero current detect threshold) needs also be set. The value of P06.18 can be 2%. The value can't be too big or too small. Too big value reduces the protection, and causes unsafe system, too small value increases the system sensitivity, creates false protection and reduces the reliability. Fig. 7.14 provides a wiring example.

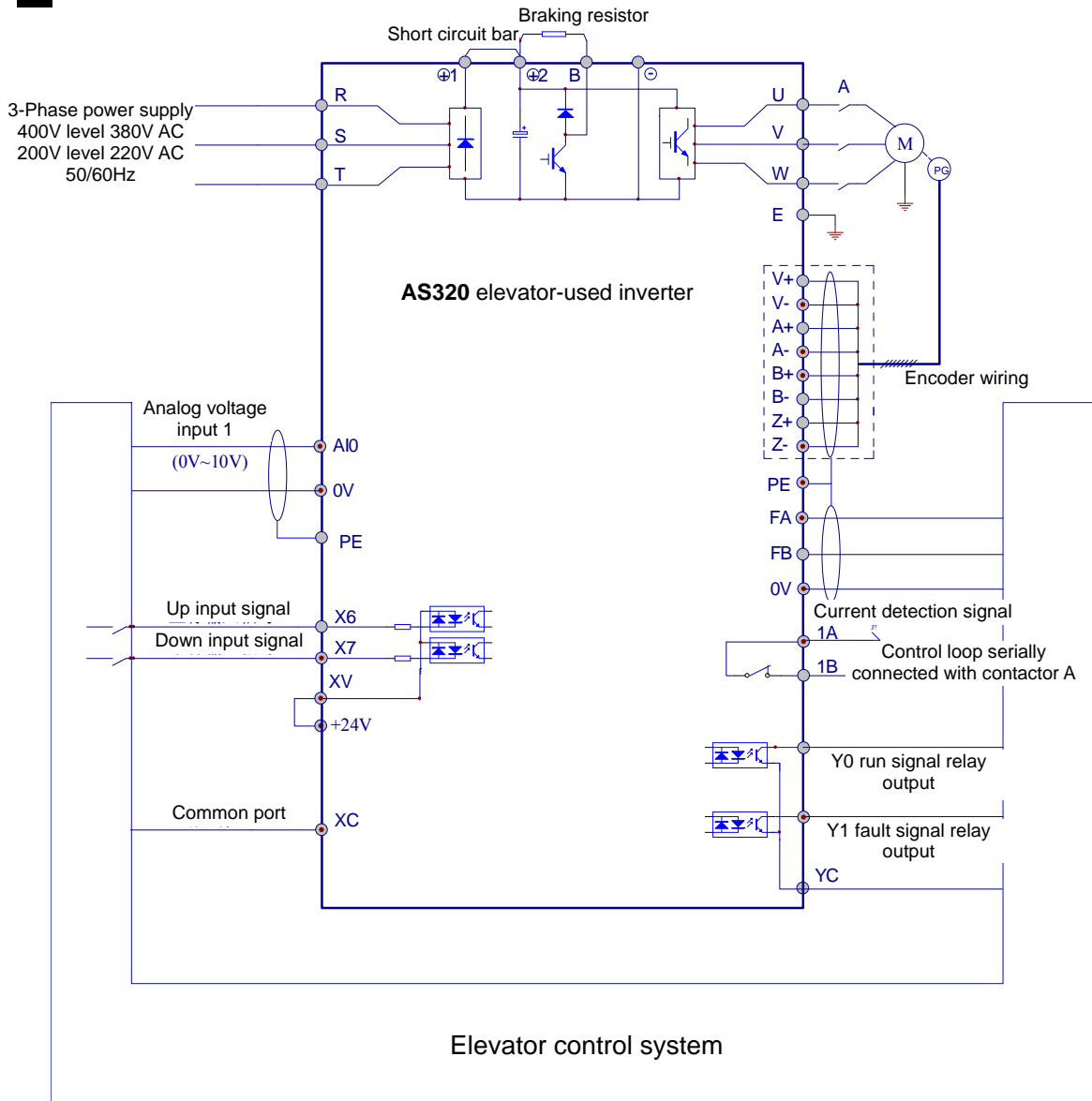

Fig. 7.14 Wiring example for one contactor

In Fig. 7.14, connecting NC contact of inverter output K1 relay into circuit of main loop contactor A. If elevator stops and flow current is detected by inverter, K1 relay closes, its NC contact is opened. Power of main loop contactor A is cut off. Contactor A can't close (or open), elevator stops operating. This design conforms to condition (b) as well.

Chapter 8 Fault Check

This chapter describes inverter faults, fault codes, contents, reasons and their solutions in details, and provides analysis flow chart for all kinds of faults during elevator adjusting or operating.

Danger

- ⦿ **Maintenance operation should start 10 minutes after power supply is cut off. At that time, charging indicator must be off completely or voltage of DC bus is lower than 24 VDC.**
Or it may cause electric shock.
- ⦿ **To retrofit inverter privately is absolutely prohibited.**
Or it may cause electric shock or human injury.
- ⦿ **Only professional electrician can perform maintenance operation. Leaving cable stub or metal obstacle inside inverter is prohibited.**
Or it may cause fire hazard

Caution

- ⦿ **Don't change wiring and connect/disconnect terminal blocks during power on.**
Or it may cause electric shock.

8.1 The function of protection and check

When inverter fault occurs, fault LED on top of digital operator blinks. LED displays the current fault code.

Inverter has total 39 fault codes. Fault list table 8.1 shows the fault codes and their reasons, solutions.

Table 8.1 Fault list

Fault code	Fault display	Possible reason	Solution
1	Module over-current protection	Too high voltage at DC terminal	Check network power for fast stop under high inertia load, no dynamic braking
		Possible short connection to peripheral circuit	Check any short circuit between motor and output connection, grounding
		Losing output phase	Check any loose connection for motor and output
		Encoder fault	Check encoder or its wiring
		Hardware poor contact or damage	Need maintenance by professional technician
		Internal component loose	Need maintenance by professional technician
		The power circuit components overheat due to the cooling fan or cooling system problem.	Check the cooling fan. Check whether the cooling fan power is blocked by dirt or foreign object.
Warning: The inverter must started only after eliminating the malfunction causes, avoiding the damage to IGBTs			
2	ADC fault	Current sensor damaged	Replace current sensor
		Problem of current sampling loop	Replace control board
3	Heatsink overheat	Ambient temperature too high	Reduce ambient temperature, increase ventilation. Keep the surrounding temperature below 40 °C or according to this character to test the capacity of the inverter.
		The cooling fan damaged or foreign object entered into the cooling system.	Check whether the fan power cable is well connected, or replace the same model fan or remove the foreign objects.
		Cooling fan is abnormal	Check the cooling fan. Check whether the cooling fan power is correct and whether there is any foreign object blocking the fan.
		Temperature detect circuit fault	Need maintenance by professional technician
4	Braking unit failure	Braking unit damaged	Replace related driving module or control circuit board
		External braking resistor circuit short	Replace the resistance or the wiring connection
5	Blown fuse failure	Fuse blown by high current	Check the fuse circuit connection, or looseness of connectors
6	Over torque output	Too low input voltage	Check input power supply
		Motor stop rotating or abrupt loading change	Prevent motor stopping, reduce abrupt loading change

Fault code	Fault display	Possible reason	Solution
		Encoder failure	Check encoder or its wiring
		Missing output phase	Check the loose connection of motor and output wiring
7	Speed deviation	Too short acceleration time	Extend acceleration time
		Too high load	Reduce load
		Too low current limit	Increase current limit under allowed range
8	Bus over voltage protection (in acceleration running)	Abnormal input voltage	Check input power supply
		Re-rapid starting during motor in high speed rotating	Wait till motor stop rotating, and re-start
	Bus over voltage protection (in deceleration running)	Too high load rotational inertia	Select proper energy consumed braking component
		Too short deceleration time	Extend deceleration time
		Too high braking resistance or no resistor	Connect proper braking resistor
	Bus over voltage protection (running at constant speed)	Abnormal input power	Check input power supply
		Too large load rotational inertia	Select proper energy consumed braking component
		Too high braking resistance or no resistor	Connect proper braking resistor
	9	Bus undervoltage	Power voltage lower than minimum equipment working voltage
Instantaneous power off			Check input power supply, reset and restart after input power back to normal
Too high fluctuation of input power voltage			
Loose power connection block			Check input wiring
Internal switch power abnormal			Need maintenance by professional technician
A large starting current load existing in the same power supply system			Alter power system to conform the specification
10	Loss of output phase	Abnormal wiring at inverter output, missing or breaking connection	Check wiring at inverter output side based on operation procedure, eliminate missing, breaking connection
		Loose output terminal block	

Fault code	Fault display	Possible reason	Solution
		Insufficient motor power, less than 1/20 of maximum applicable inverter motor capacity	Adjust the capacity of inverter or motor
		Unbalanced three phase output	Check the motor wiring Check the consistency of characteristic of inverter output side and DC side terminals
		Motor over current at low speed (during acceleration)	Low network voltage Improper motor parameter setting Rapid start during motor running The acceleration time for load inertia (GD2) is too short.
11	Motor over current at low speed (during deceleration)	Low network voltage	Check input power supply
		Too large load rotational inertia	Select proper energy consumed braking component
		Improper motor parameter setting	Set proper motor parameters
		Too short deceleration time	Extend deceleration time
		The deceleration time for load inertia (GD2) is too short	Prolong the slowdown time
	Motor over current at low speed (during constant speed)	Abrupt load change in running Improper motor parameter setting	Reduce frequency and amplitude of abrupt load change Set proper motor parameters
12	Encoder failure	Incorrect encoder connection	Correct wiring encoder
		Encoder no signal output	Check encoder and power supply
		Encoder wire disconnected	Re-connect
		Abnormal function code setting	Ensure the proper encoder function code setting
13	Current detected at stopping	Current keep on flowing while motor stops	Slip happens by synchronous motor
			Need maintenance by professional technician

Fault code	Fault display	Possible reason	Solution
14	Reversed speed during operation	Reversed speed during operation	Check the abrupt change of external load
		Phase differed between encoder and motor	Change motor or phase order
		Motor reversed by starting, current reaches the limit	Current limitation is too low or motor unmatched
15	Speed detected at stopping	Elevator slip due to loose brake	Check brake
		Encoder interfered or loose	Tighten encoder, eliminate interference
16	Wrong motor phase	Motor reversed connected	Correct connection or adjust parameter
17	Over speed in the same direction (in maximum allowed speed)	Synchronous motor over speed by loss of excitation	Check motor
		Wrong angle self-learning for synchronous motor	Re-do the self-learning
		Wrong encoder parameter or interference	Check encoder circuit
		Too large positive load or abrupt load change	Check the reason for abrupt load change
18	Over speed in opposite direction (in maximum allowed speed)	Synchronous motor over speed by loss of excitation	Check motor
		Wrong angle self-learning for synchronous motor	Re-do the self-learning
		Wrong encoder parameter or interference	Check encoder circuit
		Too large reversed load or abrupt load change	Check the reason for abrupt load change
19	UVW encoder wrong phase order	Incorrect encoder connection or wrong parameter	Check connection or change parameter
20	Encoder communication fault	Encoder fault	Check encoder wiring and re-do encoder self-learning
21	abc over current (3 phase instantaneous value)	Motor single phase shorted to earth	Check motor and output circuit
		Encoder fault	Check encoder and correct wiring
		Test loop of drive board fault	Replace drive board
22	Brake detection	Inactive output relay	Check relay control loop

Fault code	Fault display	Possible reason	Solution
	fault	Relay triggered, brake not released	Check the brake power string for loosening or breaks
		No signal detected by feedback component	Tune feedback component
23	Input over-voltage	Too high input voltage	Check whether input voltage matches inverter rating
		Problem by detection loop of switch voltage	Need maintenance by professional technician
24	UVW encoder wire broken	Encoder wiring fault	Wiring block loose or wire broken in connection
25	Reserved for future use		
26	Encoder no self-learning	Encoder angle not learned by synchronous motor	Do an encoder self-learning
27	Output over current (valid value)	Too long time operation under overload status. The larger the load, the shorter the time is.	Stop for a while, if problem occurs again after re-operation, check to ensure the load in allowed range.
		Motor blocked	Check motor or brake
		Motor coil short	Check motor
		Output short	Check wiring or motor
28	SIN/COS encoder fault	Damaged encoder or wrong wiring	Check encoder and its wiring
29	Loss input phase	Abnormal voltage at input side	Check grid voltage
		Loss input voltage phase	
		Input terminal block loose	Check input terminal wiring
30	Over speed protection (exceed maximum protected speed limit)	Wrong encoder parameter set or interference	Check encoder circuit
		Abrupt load change	Check the external reason for abrupt load change
		Wrong parameter for over speed protection	Check parameter
31	Over current at motor high speed	Power grid voltage too low	Check input power supply
		Abrupt load in operation	Reduce frequency and amplitude of abrupt load change

Fault code	Fault display	Possible reason	Solution
		Incorrect motor parameter	Set motor parameter correctly
		Wrong encoder parameter or interference	Check encoder circuit
32	Grounding protection	Wrong wiring	Refer to user manual, correct the wrong wiring
		Abnormal motor	Replace motor, to have a grounding isolation test first
		Large drain current to earth at inverter output side	Need maintenance by professional technician
33	Capacitor aged	Inverter capacitor aged	Need maintenance by professional technician
34	External fault	External fault signal input	Check the reason for external fault
35	Unbalance output	Abnormal wiring at inverter output side, missing or broking connection	Check inverter output side wiring follow the operation procedure, eliminate possible missing, broking connection
		Motor three phase unbalance	Check motor
36	Wrong parameter setting	Wrong parameter setting	Modify inverter parameter
37	Current sensor fault	Drive board hardware fault	Need maintenance by professional technician
38	Brake resistor short	Connection of external brake resistor short	Check the wiring of brake resistor
39	Too high instantaneous current	Three phase instantaneous current over and alarm while Ia, Ib and Ic not in operation	Need maintenance by professional technician
40	KMY detection fault	KMY detect contactor signal and KMY control signal don't match	Check the contactor of KMY control and KMY detection
41	Brake switch detection fault	Brake switch detect contactor signal and its control signal don't match	Check brake switch
42	IGBT short circuit protection	She cause is the same as Fault 1.	Check short circuit for motor and output wiring, grounding
44	The input power supply is abnormal	1. The input power supply changes a lot 2. Input contactor abnormally connected 3. Temporary electricity	1. Check the power supply 2. Check input contactor
45	I2t instantaneous over current	Same as fault 21,27	Same as fault 21,27

Fault code	Fault display	Possible reason	Solution
	protection		
46	I2t valid over current protection		

8.2 Fault diagnosis procedure

Because of the reasons of parameter setting, wrong wiring, inverter and motor might not run in a preset condition at first start. In this case please refer to the introduction in this section about the fault diagnosis procedure, to have fault analysis and handling.

Abnormal motor running:

1) Motor doesn't run when running command at control terminal block is sent.

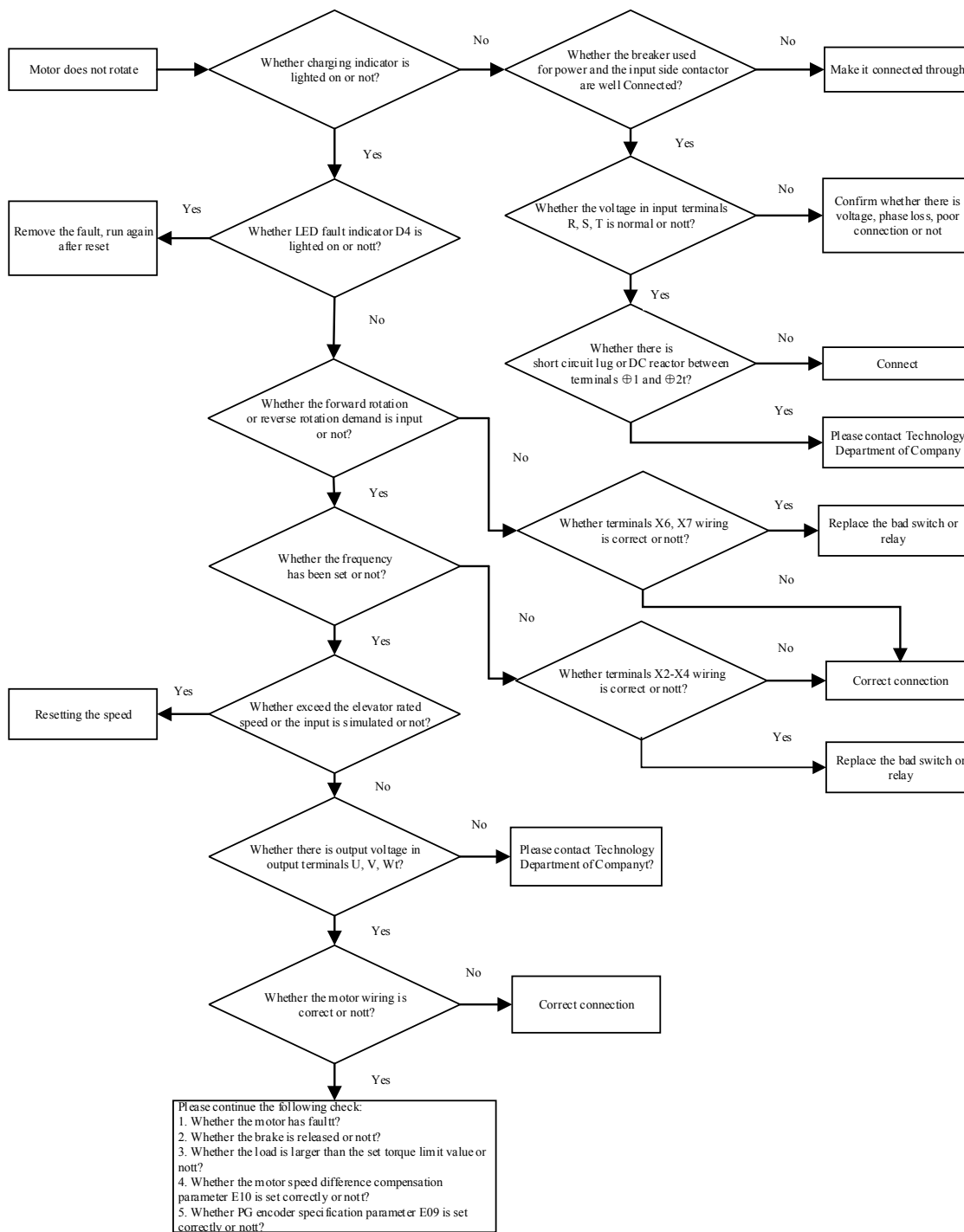

2) Motor runs but doesn't have speed change.

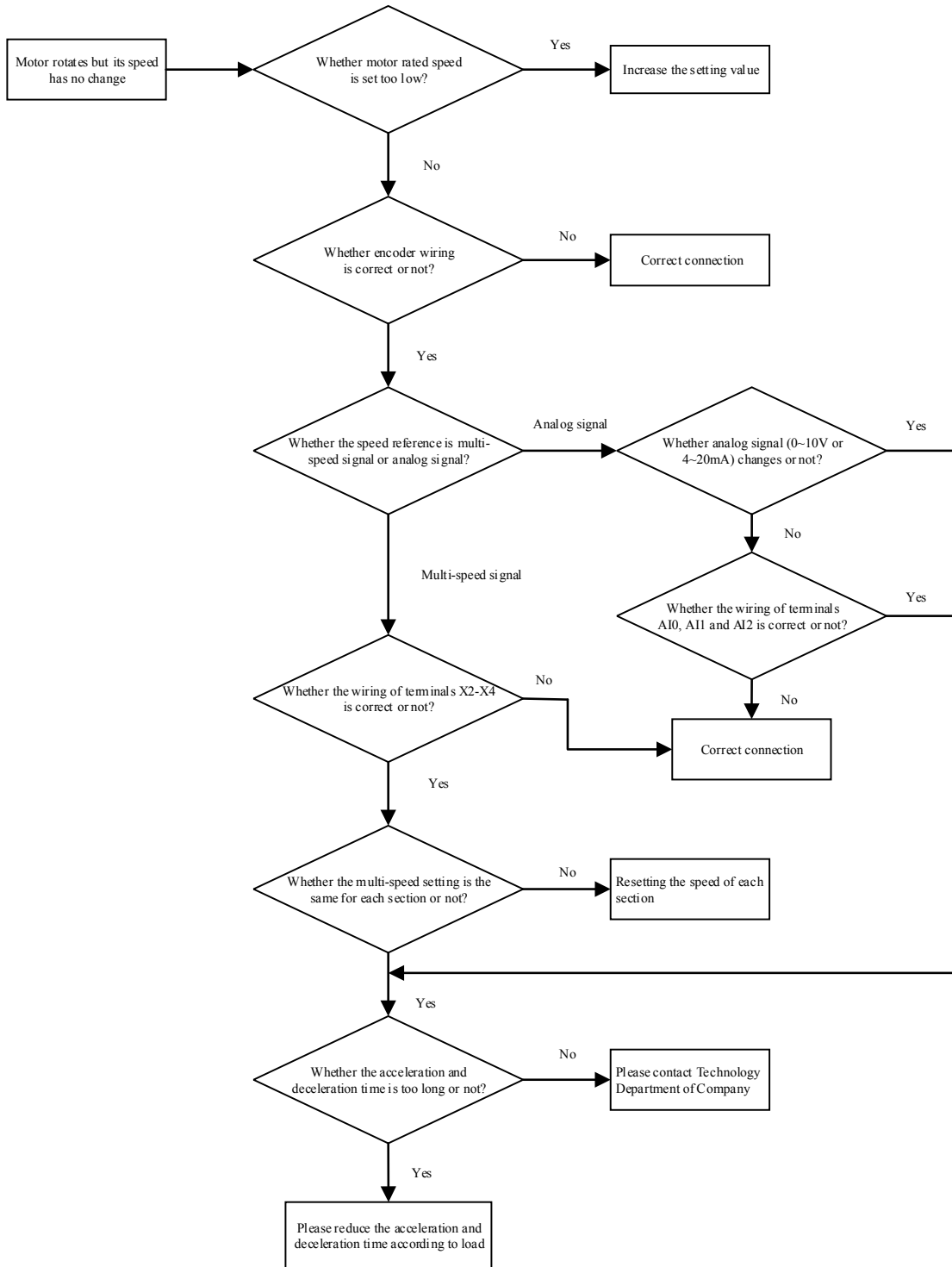

Chapter 9 Service And Maintenance

This chapter introduces the general information about service and maintenance.

Danger

- ⦿ **Maintenance should be started 10 minutes after power off. The charge indicator should be fully off and DC bus voltage should be below 24 VDC.**
Or it may cause electric shock.
- ⦿ **Never remould inverter unauthorizedly.**
Or it may cause electric shock and human injury
- ⦿ **Only professional electrician can operate the product maintenance. Never leave any wire stubs, metal pieces inside the inverter.**
Or it may cause fire hazard.

Caution

- ⦿ **Do not alter wiring and remove wiring terminal while power is on.**
Or it may cause electric shock

9.1 Warranty

Our company provides warranty service if inverter (main body) has the following situation:

Our company will be responsible for the repairs within the warranty period (counted date from leaving factory) if inverter has failure or damage in normal operation condition. An appropriate maintenance cost will be charged if the warranty period is due.

If the failure was caused by following reasons, a certain cost will occur even within warranty period:

- 1) Problem caused by not follow up instruction manual or unauthorized repair or alter
- 2) Problem caused by over specified limit usage
- 3) Drop the product or transport damage
- 4) Damage caused by earthquake, fire hazard, flood, lighting, abnormal voltage or other natural disasters, or its affiliate reason

9.2 Product inquiry

If product damages, has fault or other problem, please contact to our office or customer service department and prepare the following information:

Inverter Model

Serial number

Date of purchase

Information needs to be provided: damage description, unclear question and fault occurred

9.3 Routine check

Inverter hull can't be taken off during energizing or operation. To observe the state of operation can only go through visual check. The following items can be routinely checked:

- 1) Does ambient environment fulfill standard specification?
- 2) Does operation conform to the standard specification?
- 3) Any abnormal noise, vibration or others?
- 4) Proper working cooling fan installed in inverter?
- 5) Any over-heat situation?

9.4 Periodic check

To start a periodic check, inverter should stop operating, switch off power, then remove the hull. The charging capacitor in main circuit may still have charged voltage and needs time to discharge it. Therefore the check operation can only start after charging indicator is off and DC bus voltage measured by multimeter is lower than safety value (below 24VDC).

There will be an electric shock hazard if you touch the terminal block right after power off.

Table 9.1 lists the items needed to be periodic check.

Table 9.1 Periodic check item

Area		Item	Method	Judgment
Operation environment		1) Ensure ambient temperature, humidity, vibration, check any dust, corrosive gas, oil mist or water drop, etc 2) Any dangerous goods in surrounding area	1) Visual check, thermometer, hydrometer 2) Visual Check	1) Ambient temperature lower than 40°C. Humidity and other environment index meet the requirements 2) No dangerous good
LCD display		1) Is LCD clearly displayed? Even backlight? 2) Any missing letter in screen?	Visual check	1) Even backlight 2) Correct display
Connector Terminal block, bolt		1) Loosening bolt 2) Loosening connector	1) Tightening 2) Visual check	1) Normal condition 2) Secured installation
Main circuit	Wire	1) Shielded layer broken or faded 2) Deformed copper connector	Visual check	Normal condition
	Electromagnetic contactor, relay	1) Has vibration sound in operation 2) Is contact point proper closed	Hearing check, visual check	1) No 2) Can hear contactor closing
	Charging capacitor	1) Any leaking, color change, crack and swollen enclosure 2) Does safety valve go out? Any swollen on it?	Visual check	Normal condition
	Heatsink	1) Is dust piled up? 2) Air duct blocked or attached by foreign object	Visual check	Normal condition
	Cooling fan	1) Any abnormal noise 2) Any abnormal vibration 3) Color changed due to overheat	1) Hearing, visual check. Manual turn fan blade after power off. 2) Visual check 3) Visual check, olfaction check	1) Rotating smoothly 2), 3) no abnormalities
Control circuit	Connection component	Any dust or attached foreign object on two row terminal strip between control board and main circuit	Visual check	Normal condition
	Control board	1) Any color change or odor smell on control PCB 2) Any crack, damage, deform on PCB	1) Visual Check, olfaction check 2) Visual check	Normal condition

Appendix A Inverter EMC Installation Guide

This appendix introduces EMC inverter design, installation from aspects of noise suppression, wiring requirement, grounding, peripheral equipment surge absorption, current leakage, install area dividing, installation precaution, using power filter, and radiation noise treatment.

A.1 Noise suppression

The principle of inverter decides that a certain noise may produce. The effect to the peripheral equipments depends on the type of noise, noise transmission path, design and installation of kinetic system, wiring and grounding.

A.1.1 Types of noise

Types of noise see Fig. A.1.

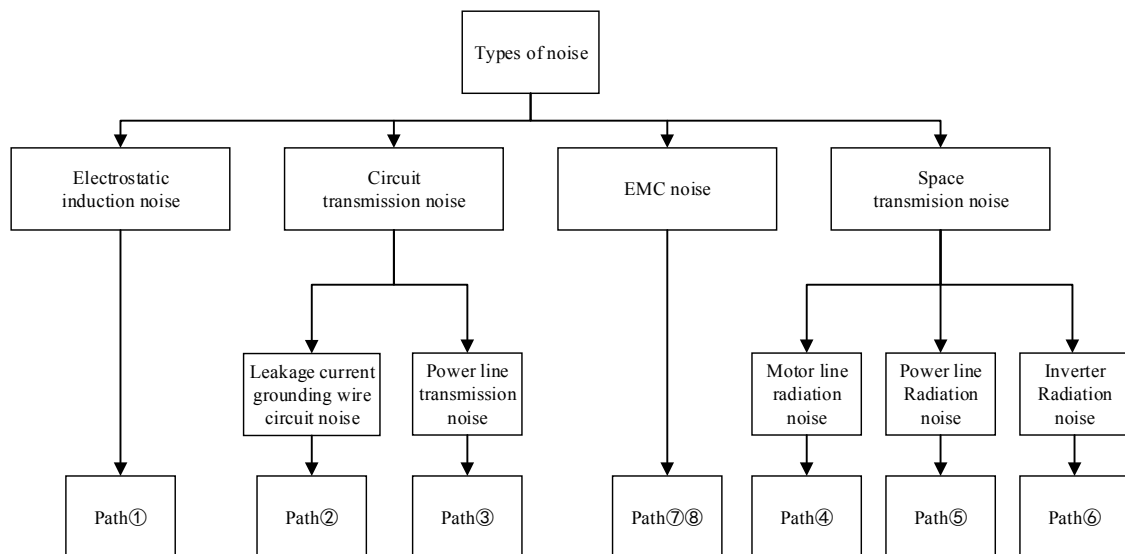

Fig. A.1 Diagram for noise type

A.1.2 Noise transmission route

Noise transmission path see Fig. A.2.

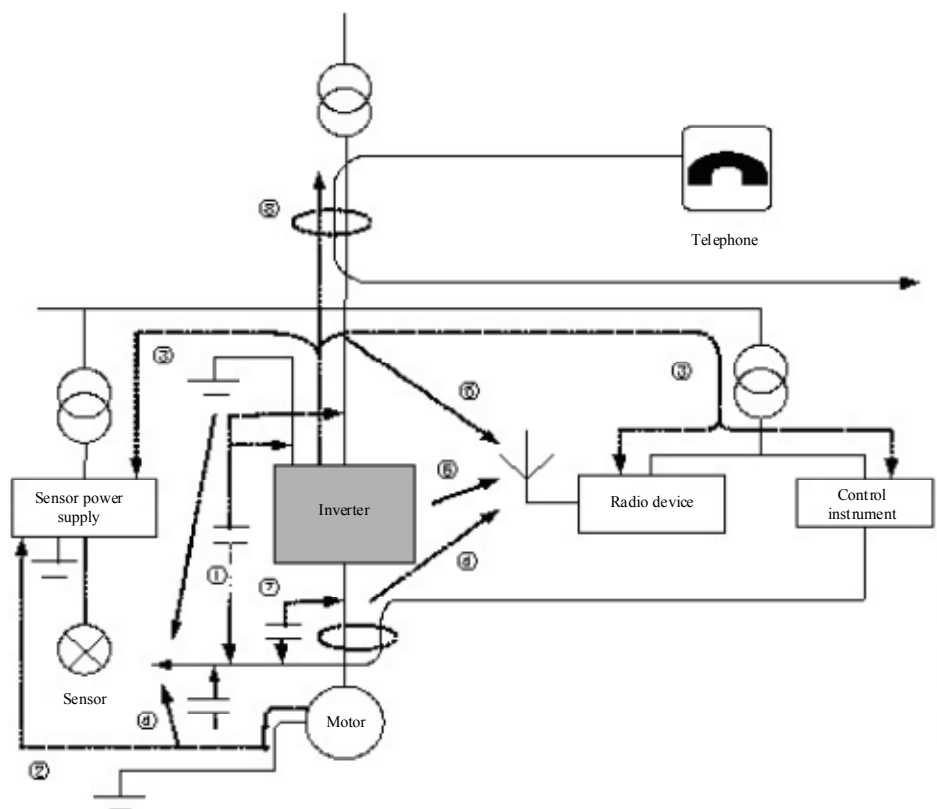

Fig. A.2 Noise transmission route

A.1.3 Basic method for noise suppression

Basic methods against noise suppression see Table A.1.

Table A. 1 Basic countermeasure for noise suppression

No.	Cause	Countermeasure
① ⑦ ⑧	If signal cable runs in parallel with power cable or they are bundled, noise will be transmitted in signal cable due to the electromagnetic induction and static induction. Peripheral device may be wrongly triggered.	1) Avoid signal cable and power cable in parallel running, or bundled; 2) Keep susceptible peripheral device far away from inverter; 3) Lay easy affected signal cable far away from inverter input/output power cable; 4) Use shielded wire for signal cable and power cable. It is better to insert into metal tube separately (minimum 20 cm between metal tubes)
②	If the peripheral device becomes a close loop circuit by wiring to inverter, the inverter grounding current leakage will cause wrong action of the peripheral device.	Don't ground the peripheral device can avoid the wrong action caused by current leakage
③	If the peripheral device shares the same power supply with inverter, noise created by inverter can be transmitted along the power cable. The peripheral devices linked in the system may cause wrong action.	Install a noise filter at inverter input side, or use isolate transformer/power filter to other peripheral devices for noise isolation
④ ⑤ ⑥	If weak current peripheral devices, such as control computer, gauges, radio device, sensor and their cable are installed in the same cabinet with inverter, and their wiring is closed to the inverter, radiate interference may cause wrong action.	1) Easy affected peripheral devices and their cable should be installed far away from inverter. Shielded cable should be used for signal cable and shielded layer grounds to the earth. Signal cable inserts into metal tube and away from inverter and its input/output power cable. A perpendicular cross must be wired in case of inevitable cable crossing between signal cable and power cable. 2) To install radio noise filter or linear noise filter (Ferrite Common Mode Choke) on both input and output side of inverter can suppress radiated noise of inverter input and output power cable. 3) Cable from inverter to motor should be inserted into a thick shield of 2mm or thicker, or be buried in a cement groove. Cable should be inserted into a metal tube and its shield should be grounded (4 core cable can be taken for motor wiring, one core grounds to earth at inverter side and connects to the motor enclosure at the other end).

A.2 Wiring requirement

A.2.1 Requirement for cable laying

In order to avoid mutual coupling of interference, control signal cable should be laid separately from power cable and as far as possible from them. Fig. A.3(a) shows this situation. Fig. A.3(b) shows that a perpendicular cross must be ensured when a signal cable must pass a power cable of power supply or motor.

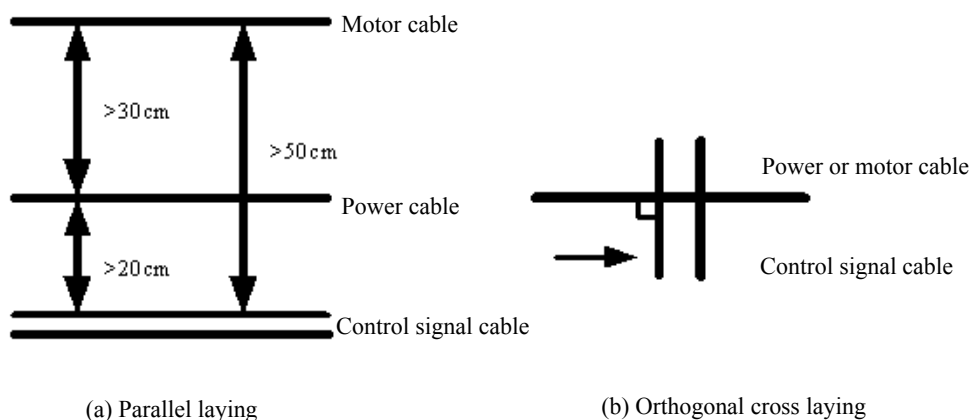

Fig. A.3 Wiring requirement

A.2.2 Requirement for cable cross section area

The larger the cable cross section is, the larger the earth capacitance, and the higher the ground current leakage will be. If the cross section of motor power cable is too large, motor should be used with decreased rating and reduces the output current (reduce 5% of current for each increasing level of cross section).

A.2.3 Requirement for shielded cable

High frequency, low impedance, shielded armor cable, such as copper mesh, aluminum mesh, should be used.

A.2.4 Installation requirement for shielded cable

Normally control cable should be a shielded cable, and shielded metal mesh should be connected to metal cabinet by 360° ring type clamp fixed. Fig. A.4 shows the correct connection. Shielded connection shown in Fig. A.5 is wrong.

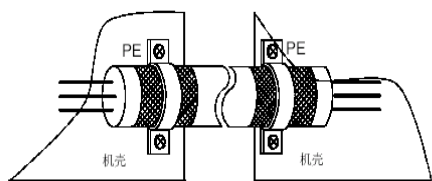

Fig. A.4 Correct shielded grounding

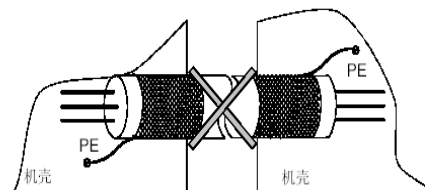

Fig. A.5 Incorrect shielded grounding

A.3 Grounding

A.3.1 Type of grounding

Fig. A.6 lists the methods for electrode to ground.

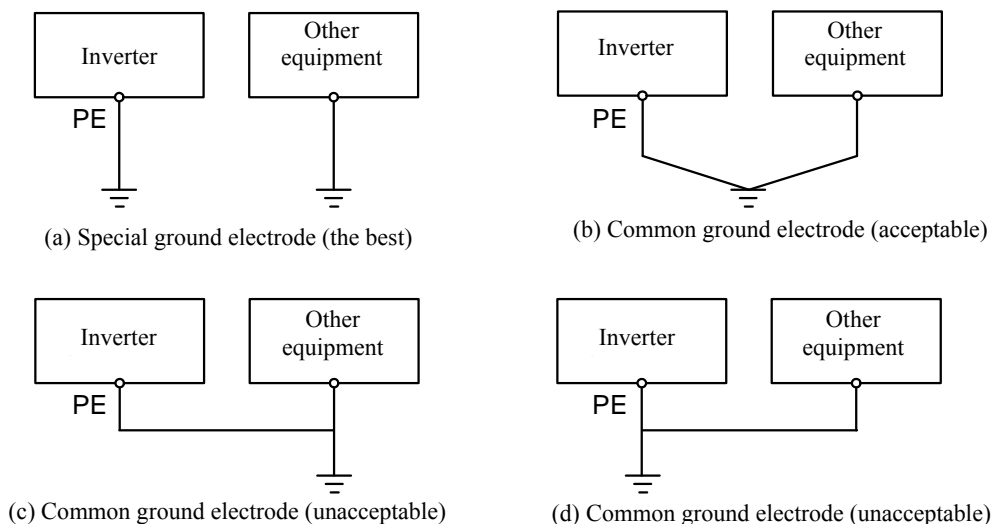

Fig. A. 6 Diagram for special grounding

Method (a) is the best grounding method in above 4 connections. It is strongly suggested for users to adopt this grounding method.

A.3.2 Precaution for ground wiring

- 1) Grounding cable must be selected to have a standard cross section in order to minimize the grounding impedance. Flat cable has less high-frequency impedance than round conductor cable, flat cable is better in this case if they have the same cross section area.
- 2) To have grounding cable as short as possible, and grounding spot should be connected to inverter as close as possible.
- 3) If motor takes 4-core cable, one core must be grounded at inverter side. Other end is connected to the motor grounding terminal. The best grounding solution is that both motor and

inverter have their individual ground electrode.

4) If all grounding terminals of different parts in control system are connected together, noise may be created because of ground current leakage. It may affect the peripheral devices other than inverter. In the same control system, grounding for inverter and other weak current devices, such as computer, sensor or audio device, should be wired separately.

5) In order to acquire low high-frequency impedance, all equipment fix bolts can be taken as high-frequency terminal to connect the cabinet back panel. Be aware to remove insulating paint before installation.

6) Grounding cable should be laid away from the I/O wiring of noise sensitive device, and should keep short.

A.4 Surge absorber installation

Relays, contactors and electromagnetic brakes can create large amount of noise. Surge absorber needs to be installed even those components aren't inside the inverter case. Wiring is shown in Fig. A.7.

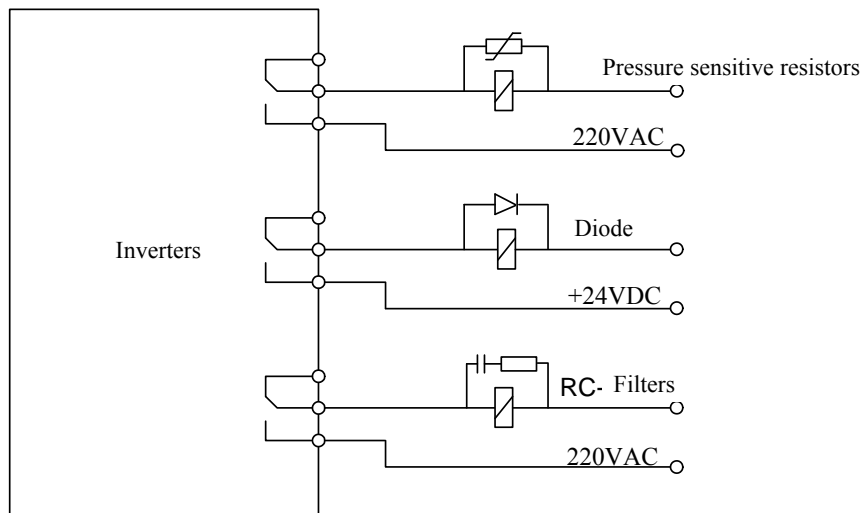

Fig. A.7 Requirement for relay, contactor, EM brake

A.5 Leakage current and its solution

Leakage current flows through the linear capacitor and motor capacitor at input/output side of inverter. Current as shown in Fig. A.8, includes ground leakage current and interline leakage current. The amount of leakage current is decided by the size of carrier frequency and capacitance.

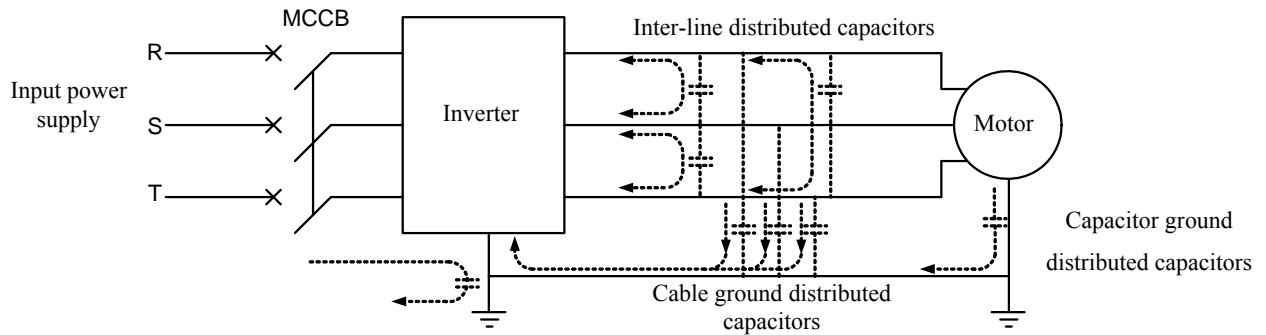

Fig. A.8 Leakage current path

A.5.1 Ground leakage current

Besides inverter, ground leakage current can also flow into other devices by grounding cable. It might trigger the wrong action of leakage current breaker, relay or other devices. The higher the inverter carrier frequency, the longer the motor cable is, the higher the leakage current will be.

Suppression measure: lower carrier frequency; short motor cable, take special designed leakage breaker for ultraharmonics/surge.

A5.2 Cable inter-line leaking

The leakage current flowed through distributed interline capacitors at inverter output side, may trigger the wrong action of external thermal relay due to its ultraharmonics. Especially for small inverter which capacity is below 7.5 KW, the long cable (more than 50m) causes increasing leakage current. External thermal relay is easy wrongly triggered.

Suppression measure: lower carrier frequency; install AC output reactor at output side; recommend to use temperature sensor and monitor the motor temperature directly, or to use electronic thermal relay for motor overload protect carried by inverter to replace external thermal relay.

A.6 Radiation suppression

Normally inverter is installed in a metal cabinet. Only minor radiation may affect the devices outside the metal cabinet. The main radiation source is the power cable connected externally. Since all inverter power cable, motor cable, control cable and keyboard wire need to be wired to outside of shielded cabinet, the outgoing position should be special handled, or shield will be invalid.

In Fig. A.9, part of cable inside the shielded cabinet plays as antenna. It picks up noise radiation in the cabinet and transmits to the outside air via cable. In Fig. A.10, wiring cable shielded layer to cabinet grounding at the outlet, noise radiation picked up in the cabinet will then flow into the earth directly via shielded cabinet, and will not affect the environment.

By using shielded layer grounding introduced in Fig. A.10, the place where cable shielded layer connects to the grounding cabinet should be close to the cable outlet, otherwise the unshielded cable between grounding point and outlet will still be functioned as antenna and have coupling affection.

The distance between grounding point and outlet should be less than 15cm, the short, the better.

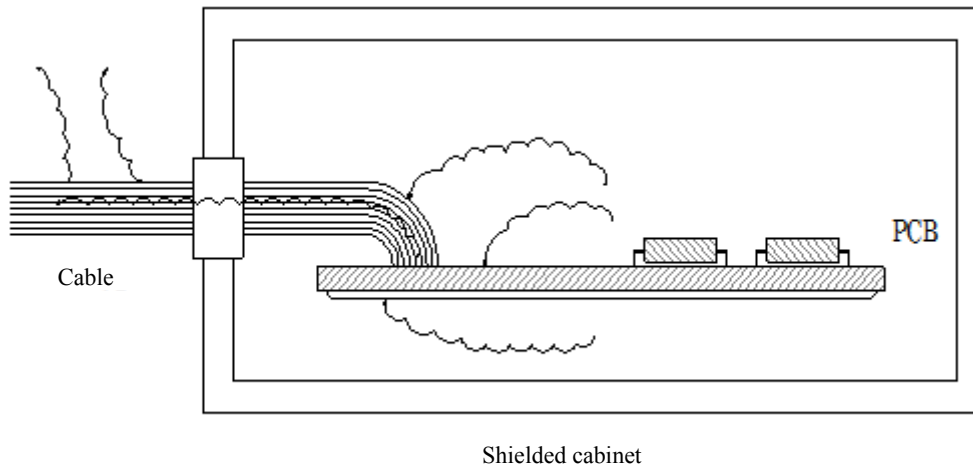

Fig. A.9 Radiation brought by cables from shielded cabinet

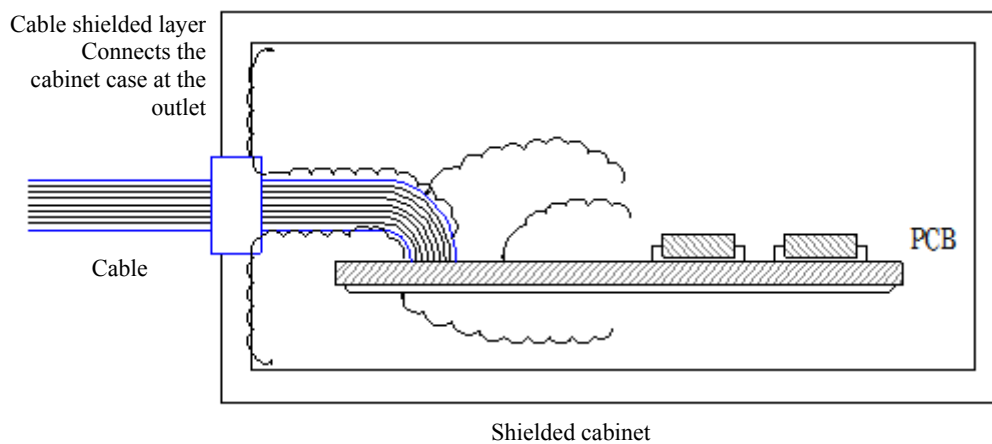

Fig. A.10 Cable shielded layer connects to shielded cabinet and suppress the radiation

A.7 Power cable filter guide

Devices which create strong interference or are sensitive to surrounding interference can use power cable filter.

A.7.1 Function of power cable filter

1) Power cable filter is a dual low-pass filter, it allows only DC and current with 50Hz. High frequency electromagnetic interference current is not allowed to pass. It can not only suppress electromagnetic interference created by device itself into the power cable, but also prevent interference on power cable into the device.

2) Power cable filter can meet both criterion for conduct emission and conduct susceptibility EMC. It can suppress the radiation interference at the same time.

A.7.2 Precaution for power cable filter installation

1) In cabinet, filter should be installed to the inlet of power cable as close as possible. The filter power cable inside the cabinet should keep short.

2) If filter input and output cable are laid to close, high frequency interference will bypass the filter and start to couple directly. Power cable filter will lose the function.

3) Normally, there is a designated grounding terminal on filter enclosure. If only one conductor is used to connect filter grounding terminal to the cabinet, filter will not be properly functional due to the high frequency impedance of long conductor. The correct way is to attach the filter enclosure to the metal conductive surface of cabinet and possible keep the large contact area. Note to remove insulating paint, ensure good electrical contact.

A.8 Installation section divide for EMC inverter

In the driving system consist of inverter and motor, inverter and the peripheral devices, such as controller, sensors, are normally installed in the same cabinet. Control cabinet can suppress the outside interference by taking measures at the main conjunction. Therefore radio noise filter and input cable AC reactor should be installed at input cable terminal in control cabinet. To meet the EMC requirement, Electromagnetic Compatibility (EMC) should also be fulfilled inside the cabinet.

In the driving system consist of inverter and motor, inverter, brake unit and contactors are all sources of high noise intensity. It will affect the noise sensitive peripheral devices, such as automation equipments, encoder and sensors. Based on their electrical characteristics they can be installed in different EMC zones. The most effective measure to reduce interference is to separate the noise source and noise receiver in space. Fig. A.11 shows the division of inverter EMC installation zone.

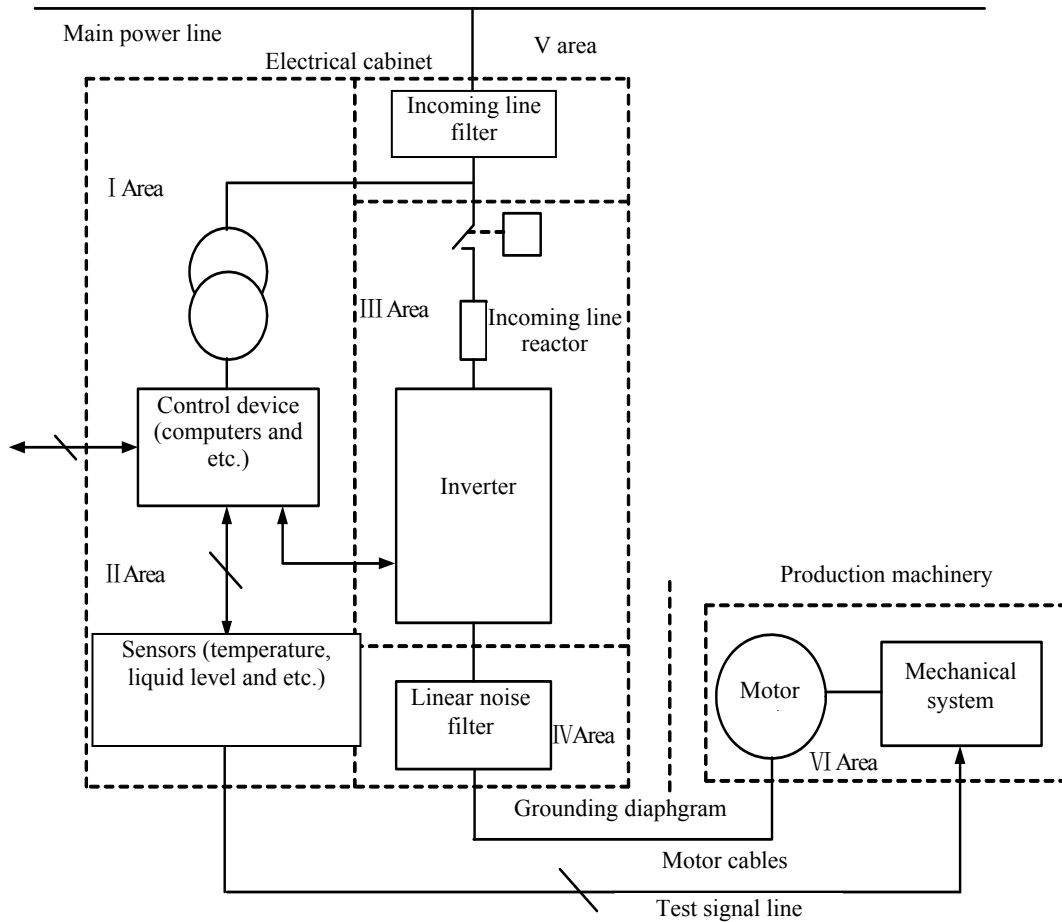

Fig. A. 11 Diagram for inverter EMC installation zone

Above installation zones are described as follows:

Zone I: control power transformer, control device, sensors and etc.

Zone II: control signal cables and their connection, require certain ability for anti-interference

Zone III: major noise source includes incoming cable reactor, inverter, brake unit, contactors etc.

Zone IV: Output noise filter and its wiring

Zone V: Power supply (include wiring of radio noise filter)

Zone VI: Motor and its cable

Each zone must be separated and keep a minimum 20cm distance to avoid electromagnetic coupling. The grounded separator is the best to divide each zone for coupling. Cables in different zones should be inserted into individual cable ducts. When filter is required, it should be installed at entrance point of each zone. All bus cables (such as RS485) and signal cables from cabinet must be shielded.

A.9 Precaution for electrical installation

Fig. A.12 shows the inverter electrical installation.

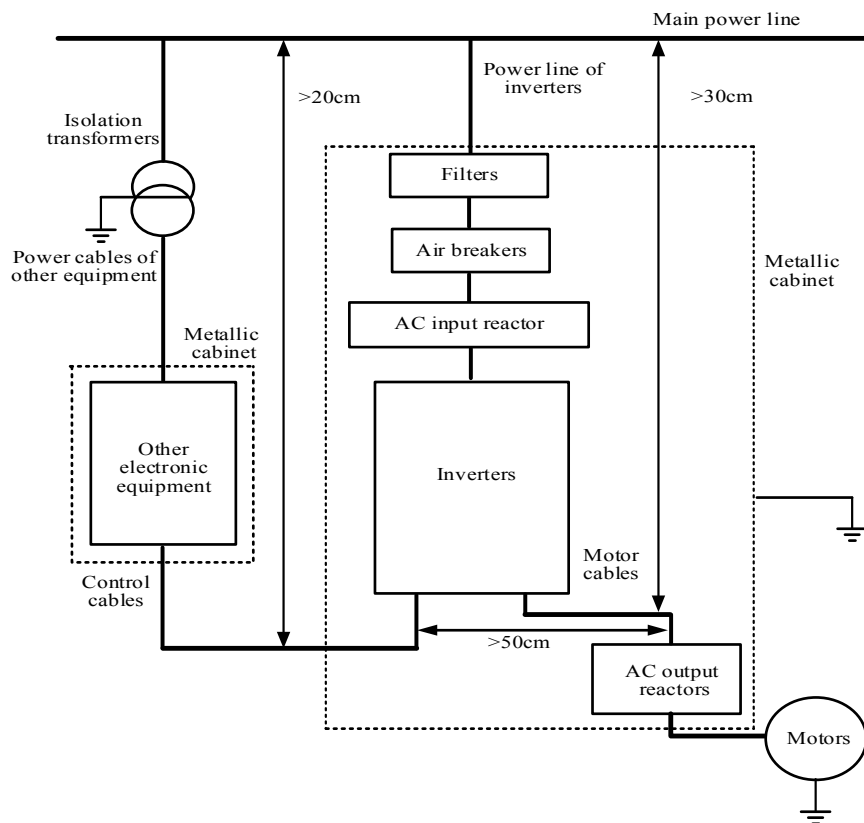

Fig. A. 12 Inverter electrical installation diagram

To satisfy requirement of EMC, please note during installation:

1) Inverter should be installed inside the cabinet. Enclosure of devices, such as inverter back panel, input filter enclosure, all must be installed on the back of control cabinet firmly, and ensure having good electrical contact between them; to minimize the space between inverter and filter, a space less than 15cm can maximum reduce the grounding cable high frequency impedance between inverter and input filter, reduce high frequency noise.

2) At entrance of control cabinet (not more than 5 cm from the outlet) installs a wide grounding block. To ensure a good electrical contact, all input, output cable shielded layers should be connected to the grounding block and fixed by 360° ring type clamp.

3) Motor cable must use shielded cable, and the best to have metal interlocked conduit, or double layers of metal mesh shielded cable. The 360° ring type clamp (such as Fig. A.4) must be used as metal cable clamp to fix the shielded layer of motor cable at inverter side to the back board of cabinet. There are two fixing locations: one is to close the inverter (the best is less than 15 cm), other location is to fix it on the ground block. 360° ring type connection should be taken to connect the motor metallic case when shielded layer of motor cable goes through the motor terminal box at motor side. If this type of connection is hard to do, the shielded layer can be braided, stretched and connected to the motor ground terminal. The stretched width should be greater than 1/5 of the braid

length. The length of motor cable core and cable from PE flexible pipe should be as short as possible. The best is to keep it less than 5 cm.

4) Shielded cable must be taken for terminal block control cable. Its shielded layer should be connected to the ground block at the cabinet entrance and taken 360° ring type metal clamp. At inverter side shielded layer can be fixed on inverter metal case by using metal cable clamp. If that way is difficult to use, the shielded layer can be woven to a broad and short braid, and connect to the PE terminals after stretched. The best length of cable core and cable from PE flexible pipe should keep less than 15 cm.

5) Keyboard cable can't go out of the shielded cabinet.

6) The holes or seams on shielded cabinet should keep small and not more than 15cm.

A.10 EMC standard fulfilled by AS320 series elevator inverter

AS320 series elevator inverter can meet the EMC standard as shown in Table A.2 after installing proper I/O filter, AC reactor (refer to the ACCESSORIES SELECTION for the proper type of filter and reactor) and following above mentioned wiring precautions.

Table A.2 AS320 series elevator inverter EMC performance summary

Item	Criteria	Level of satisfying criteria
Conducted harassment emission	EN12015.1998	$0.15 \leq f < 0.50\text{MHz}$, $100\text{dB}(\mu\text{v/m})$ ——Quasi-peak valu $0.50 \leq f < 5.0\text{MHz}$, $86\text{dB}(\mu\text{v/m})$ ——Quasi-peak valu $5.0 \leq f < 30\text{MHz}$, $90\sim 70\text{dB}(\mu\text{v/m})$ ——Quasi-peak valu
Radiated harassment emission	EN12015.1998	$30 \leq f < 230\text{MHz}$, $40\text{dB}(\mu\text{v/m})$ ——Quasi-peak valu $230 \leq f < 1000\text{MHz}$, $47\text{dB}(\mu\text{v/m})$ ——Quasi-peak valu
Electrostatic discharge immunity	EN12016.2004	Criteria B (contact discharge 4000V, air discharge 8000V)
Radiated electromagnetic field immunity	EN12016.2004	Level 3 Criteria A(3V/m)
Electrical Fast Transient (EFT) Immunity	EN12016.2004	Level 4 Criteria B (heavy current end $\pm 2\text{KV}/2.5\text{kHz}$)
Surge immunity	EN12016.2004	Criteria B($\pm 1\text{KV}$)
Conducted immunity	EN12016.2004	Criteria A(3V,0.15~80MHz)

Appendix B Full List Of Function Parameters, Fault List

This appendix summarizes the function parameters, operation status and fault lists. It's an easy reference guideline for inverter user.

B.1 Function parameters list

Function code	Name	Content	Setting range	Unit	Factory default	Remarks
P00	Password parameter and basic control mode					
P00.00	Password	It's login password. User can modify parameter only after signing in a correct password. (same as previous password set in P00.01)	0~ 65535	×	0	
P00.01	Modify or set password	Set parameter to set or modify inverter password. "0" means no password protected. It's a hidden parameter and doesn't display after setting.	0~ 65535	×	0	
P00.02	Basic control mode	Set inverter basic mode: 0: Voltage vector V/F control mode 1: Vector control without speed sensor 2: Torque control with speed sensor 3: Vector control with speed sensor	0 / 1 / 2 /3	×	3	
P00.03	Input command mode	Input command setting: 0: Panel 1: Terminal	0/1	×	1	

Function code	Name	Content	Setting range	Unit	Factory default	Remarks
P00.04	Language	Setting operator language: 0: Chinese 1: English	0/1	×	0	Can't be reset
P00.05	Version	Inverter version number			104.02	
P00.06	Two wire operation mode	0: Two wire 1, 1: Two wire 2 2: Three wire 1, 3: three wire 2			0	
P00.07	Inertia stop mode	0: Inertia stop 1: Deceleration stop 2: Decelerate + DC brake 3: Decelerate + keep excitation	0/1/2/3		0	
P00.08	Keeping frequency at stopping		0~300	Hz	0.00	
P00.09	Time for keeping frequency at stopping		0~99.9	S	0.0	
P00.10	Time for keeping excitation at stopping		0~99.9	S	0.0	
P01	Motor and encoder parameters, self-learning commands					
P01.00	Motor type	0: Asynchronous; 1: Synchronous	0 / 1	×	0	
P01.01	Motor rated power	Set rated power for traction motor	0.40~ 160.00	KW	as per inverter specification	As per motor nameplate
P01.02	Motor rated current	Set rated current for traction motor	0.0~ 300.0	A	As per inverter specification	As per motor nameplate
P01.03	Motor rated frequency	Set rated frequency for traction motor	0.00~ 120.00	Hz	50.00	As per motor nameplate

Function code	Name	Content	Setting range	Unit	Factory default	Remarks
P01.04	Motor rated rpm	Set rated rpm for traction motor	0~3000	rpm	1460	As per motor nameplate
P01.05	Motor rated voltage	Set rated voltage for traction motor	0~460	V	As per inverter specification	As per motor nameplate
P01.06	Motor poles	Set poles of traction motor	2~128	×	4	As per motor nameplate
P01.07	Motor rated slip frequency	Set rated slip frequency for traction motor	0~10.00	Hz	1.40	Refer to formula in 6-5
P01.08	Motor phase sequence	Set phase sequence of input voltage of traction motor, to modify the direction of motor running 1: Clockwise 0: Counterclockwise	0 / 1	×	1	
P01.09	Motor no-load rated current coefficient	Set proportion value of no-load current in rated current of traction motor	0.00~60.00	%	32.00	No required normally
P01.10	Motor stator resistance	Resistance of traction motor stator	0.000~65.000	Ω	As per inverter power	Only for asynchronous motor
P01.11	Motor rotor resistance	Resistance of traction motor rotor	0.000~65.000	Ω	As per inverter power	Only for asynchronous motor
P01.12	Motor stator inductance	Inductance of traction motor stator	0.0000~6.0000	H	As per inverter power	Only for asynchronous motor
P01.13	Motor rotor inductance	Inductance value of traction motor rotor	0.0000~6.0000	H	As per inverter power	Only for asynchronous motor
P01.14	Motor mutual inductance	Mutual inductance value of traction motor	0.0000~6.0000	H	As per inverter power	Only for asynchronous motor
P01.15	Encoder type	Set encoder type used for motor speed detect 0: Incremental encoder 1: SIN/COS encoder 2: Endat encoder	0/1/2	×	0	

Function code	Name	Content	Setting range	Unit	Factory default	Remarks
P01.16	Encoder pulse number	Number of pulses for an encoder cycle	500~16000	PPr	1024	
P01.17	Encoder phase angle	Value of encoder phase angle	0.0~360.0	Degree	0.0	The value obtains automatically by first running of inverter. Only for synchronous motor
P01.18	Encoder filtering time	Filtering time constant while setting encoder feedback speed input	1~30	ms	0	
P01.19	Encoder feedback direction	Set encoder feedback speed direction 1: Positive sequence 0: Negative sequence	0 / 1	×	1	
P01.20	Inverter input voltage	Set inverter input voltage	0~460	V	380	Can't initialize after setting
P02	Parameters for PID regulator, starting and braking					
P02.00	Zero servo gain P0	PID regulator gain value under zero servo	0.00~655.35	×	130.00	Recommend adjusting range: min – half of default value; max – twice as default value
P02.01	Zero servo integral I0	PID regulator integral value under zero servo			80.00	Recommend adjusting range: min – half of default value; max – twice as default value
P02.02	Zero servo differential D0	PID regulator differential value under zero servo			0.50	Recommend adjusting range: min – half of default value; max – twice as default value
P02.03	Low speed gain P1	PID regulator gain value effected only when speed reference lower than switch frequency F0			70.00	Recommend adjusting range: min – half of default value; max – twice as default value
P02.04	Low speed integral I1	PID regulator integral value effected only when speed reference lower than switch frequency F0			30.00	Recommend adjusting range: min – half of default value; max – twice as default value
P02.05	Low speed differential D1	PID regulator differential value effected only when speed reference lower than switch frequency F0			0.50	Recommend adjusting range: min – half of default value; max – twice as default value

Function code	Name	Content	Setting range	Unit	Factory default	Remarks
P02.06	Middle speed gain P2	PID regulator gain value effected when speed reference between switch frequency F0 and F1			120.00	
P02.07	Middle speed integral I2	PID regulator integral value effected when speed reference between switch frequency F0 and F1			25.00	
P02.08	Middle speed differential D2	PID regulator differential value effected when speed reference between switch frequency F0 and F1			0.20	
P02.09	High speed gain P3	PID regulator gain value effected only when speed reference higher than switch frequency F1			140.00	Recommend adjusting range: min – half of default value; max – twice as default value
P02.10	High speed integral I3	PID regulator integral value effected only when speed reference higher than switch frequency F1			5.00	Recommend adjusting range: min – half of default value; max – twice as default value
P02.11	High speed differential D3	PID regulator differential value effected only when speed reference higher than switch frequency F1			0.10	Recommend adjusting range: min – half of default value; max – twice as default value
P02.12	Low speed switch frequency F0	Set switch frequency parameter of PID regulator for low speed point, it is based on the percentage number of rated frequency. If rated frequency is 50Hz, the needed switch frequency F0 is 10Hz, 20 should be set, because 10Hz is 20% of 50Hz.	0.~ 100.0	%	1.0	
P02.13	High speed switch frequency F1	Set switch frequency parameter of PID regulator for high speed point, it is based on the percentage number of rated frequency. If rated frequency is 50Hz, the needed switch frequency F0 is 40Hz, 80 should be set,	0.0~ 100.0	%	50.0	

Function code	Name	Content	Setting range	Unit	Factory default	Remarks
		because 40Hz is 80% of 50Hz				
P02.14	Excitation time	When inverter receives operation command, operation signal sends out after this time of excitation. Brake is released	0.0~ 10.0	s	0.3	No applicable for controlling synchronous motor
P02.15	Zero servo time	The time for keeping torque from inverter sends out operation signal to accelerate elevator	0.0~ 30.0	s	0.5	
P02.16	Brake release time	Mechanical action time for braking	0.00~ 30.00	s	0.25	
P02.17	PWM carrier frequency	Set value of PWM carrier frequency	1.100~ 11.000	kHz	6.000	Normally unchanged
P02.18	PWM carrier width	Set changing value of PWM carrier width	0.000~ 1.000	kHz	0.000	Normally unchanged
P02.19	Current slow descent down time	Time from remove inverter operation command to inverter zero current output	0.00~ 10.00	s	0.00	
P02.20	Regulator mode	0: Fast mode 1: Standard mode 2: Moderate mode 3: Slow mode	0/1/2/3	×	1	
P03	Parameters for speed reference					
P03.00	Type of speed reference	0: Panel setting 1: Digital controlled multi-section speed reference 4: AI0 analog speed reference 6: AI1 analog speed reference	0 / 1 / 4 / 6	×	4	Invalid when P00.02 is set to 2
P03.01	Acceleration time	The parameter determines accelerate slope of elevator (the constant acceleration). It is an acceleration time for elevator from zero speed to maximum speed under constant acceleration. Please note, it is not a mean	0.10~ 60.00	s	2.50	Only used in multi-section speed reference

Function code	Name	Content	Setting range	Unit	Factory default	Remarks
		acceleration. Mean acceleration relates also two accelerate rounds size beside this value.				
P03.02	Deceleration time 1	The parameter determines decelerate slope of elevator (the constant deceleration). It is a deceleration time for elevator from maximum speed to zero speed under constant deceleration. Please note, it is not a mean deceleration. Mean deceleration relates also two decelerate rounds size beside this value.	0.10~ 60.00	s	2.50	Only used in multi-section speed reference
P03.03	Time for acceleration round 0	Set time for acceleration round at starting section in S curve. The longer the time is, the bigger the round is.	0.00~ 10.00	s	1.30	Only used in multi-section speed reference
P03.04	Time for acceleration round 1	Set time for acceleration round at constant speed section in S curve. The longer the time, the bigger the round is.	0.00~ 10.00	s	1.30	Only used in multi-section speed reference
P03.05	Time for deceleration round 0	Set time for deceleration round at decelerating section in S curve. The longer the time, the bigger the round is.	0.00~ 10.00	s	1.30	Only used in multi-section speed reference
P03.06	Time for deceleration round 1	Set time for deceleration round at decelerating end section in S curve. The longer the time, the bigger the round is.	0.00~ 10.00	s	1.30	Only used in multi-section speed reference
P03.07	Speed reference 1	Set speed reference 1 at digital multi-section speed reference in unit of Hz.	0.00~ 60.00	Hz	2.50	Only used in multi-section speed reference
P03.08	Speed reference 2	Set speed reference 2 at digital multi-section speed reference in unit of Hz.	0.00~ 60.00	Hz	1.20	Only used in multi-section speed reference

Function code	Name	Content	Setting range	Unit	Factory default	Remarks
P03.09	Speed reference 3	Set speed reference 3 at digital multi-section speed reference in unit of Hz.	0.00~ 60.00	Hz	1.50	Only used in multi-section speed reference
P03.10	Speed reference 4	Set speed reference 4 at digital multi-section speed reference in unit of Hz.	0.00~ 60.00	Hz	5.00	Only used in multi-section speed reference
P03.11	Speed reference 5	Set speed reference 5 at digital multi-section speed reference in unit of Hz.	0.00~ 60.00	Hz	25.00	Only used in multi-section speed reference
P03.12	Speed reference 6	Set speed reference 6 at digital multi-section speed reference in unit of Hz.	0.00~ 60.00	Hz	40.00	Only used in multi-section speed reference
P03.13	Speed reference 7	Set speed reference 7 at digital multi-section speed reference in unit of Hz.	0.00~ 60.00	Hz	50.00	Only used in multi-section speed reference
P03.14	Speed reference 8	Set speed reference 8 at digital multi-section speed reference in unit of Hz.	0.00~ 60.00	Hz	0.00	Only used in multi-section speed reference
P03.15	Speed reference 9	Set speed reference 9 at digital multi-section speed reference in unit of Hz.	0.0~ 60.0	Hz	0.0	Only used in multi-section speed reference
P03.16	Speed reference 10	Set speed reference 10 at digital multi-section speed reference in unit of Hz.	0.0~ 60.0	Hz	0.0	Only used in multi-section speed reference
P03.17	Speed reference 11	Set speed reference 11 at digital multi-section speed reference in unit of Hz.	0.0~ 60.0	Hz	0.0	Only used in multi-section speed reference
P03.18	Speed reference 12	Set speed reference 12 at digital multi-section speed reference in unit of Hz.	0.0~ 60.0	Hz	0.0	Only used in multi-section speed reference
P03.19	Speed reference 13	Set speed reference 13 at digital multi-section speed reference in unit of Hz.	0.0~ 60.0	Hz	0.0	Only used in multi-section speed reference
P03.20	Speed reference 14	Set speed reference 14 at digital multi-section speed reference in unit of Hz.	0.0~ 60.0	Hz	0.0	Only used in multi-section speed reference
P03.21	Speed reference 15	Set speed reference 15 at digital multi-section speed reference in unit of Hz.	0.0~ 60.0	Hz	0.0	Only used in multi-section speed reference
P03.22	Creep speed selection	Parameter for creep speed section	0 or 3.07~3.		0.00	Only used in multi-section speed reference

Function code	Name	Content	Setting range	Unit	Factory default	Remarks
			21			
P03.23	Stop section speed	Parameter for stop speed section	0 or 3.07~3.21		0.00	Only used in multi-section speed reference
P03.24	Deceleration time 2	Speed reducing time from crawling to stopping	0~360.0 0	s	5.00	
P03.25	Select acceleration round 1	Before end of acceleration, and target speed is slower than current speed, set this parameter to determine the execution of acceleration round 1.	0~5		0	0: Normal round 1: 1/2 of normal round 2: 1/4 of normal round 3: 1/8 of normal round 4: 1/16 of normal round 5: No round
P04	Parameters for torque reference and torque compensation					
P04.00	Torque reference mode	0: Panel setting 1: AI0 analog torque reference 2: AI1 analog torque reference	0/1/2	×	0	When torque reference mode is not used in most case, this value is set to 0. If this mode is used, speed reference mode needs to be off. (P03.00 set to 0) It is valid only when the value of P00.02 is 2
P04.01	Torque compensation reference mode	0: No torque compensation 1: Compensation based on light/heavy load switch 2: AI0 analog torque reference 3: AI1 analog torque reference	0/1/2/3	×	0	
P04.02	Direction of torque compensation	0: Positive direction 1: Opposite direction	0/1	×	0	
P04.03	Torque compensation gain	Set torque compensation gain	0.0~200.0	%	100.0	Only valid when P04.01 is set to 2~3

Function code	Name	Content	Setting range	Unit	Factory default	Remarks
P04.04	Torque compensation offset	Set torque compensation offset	0.0~100.0	%	0.0	Only valid when P04.01 is set to 2~3
P04.05	Light load switch compensation	Set compensation of downward torque when light load switch triggered	0.0~100.0	%	0.0	Only valid when P04.01 is set to 1
P04.06	Heavy load switch compensation	Set compensation of upward torque when heavy load switch triggered	0.0~100.0	%	0.0	Only valid when P04.01 is set to 1
P04.07	Output torque limit	Set output torque limit, it is a percentage value of rated torque	0~200	%	175	
P04.08	ARD operation speed	Operation speed in ARD mode	0~655.3 5	Hz	0	Only valid in ARD operation mode. The parameter is unfunctional if the value is 0
P04.09	ARD torque limit	Set torque limit in ARD operation mode	0~200	%	150	Only valid in ARD operation mode
P04.10	Sliding coefficient	Set the sliding parameter	0/6606~ 6616		0	It can run for 10 times without the current limitation by set to 6616. It exists lots of risk
P05	Parameter for digital input					
P05.00	Definition of X0 input terminal function	Digital input function code: 0: No function (The port is invalid) 3: Digital multi-section speed reference 0	0~20 103~ 120	×	0	Factory setting: P05.02=3: Terminal X2 inputs multi-section speed reference 0 P05.03=4: Terminal X3 inputs multi-section speed reference 1 P05.04=5: Terminal X4 inputs multi-section speed reference 2 P05.06=7: Terminal X6 inputs up going signal P05.07=8: Terminal X7 inputs down going signal P05.05=18: Terminal X5 inputs base block signal
P05.01	Definition of X1 input terminal function	4: Digital multi-section speed reference 1 5: Digital multi-section speed reference 2			0	
P05.02	Definition of X2 input terminal function	6: Digital multi-section speed reference 3 7: Up going command			3	
P05.03	Definition of X3 input terminal function	8: Down going command 13: External reset signal 14: External fault signal 15: External encoder phase			4	

Function code	Name	Content	Setting range	Unit	Factory default	Remarks	
P05.04	Definition of X4 input terminal function	angle adjusting command 16: Operating in emergency power supply 17: Weighing compensation			5		
P05.05	Definition of X5 input terminal function	input (for special user only) 18: Base block signal 19: Light load compensation switch			18		
P05.06	Definition of X6 input terminal function	20: Heavy load compensation switch 21: Output contactor testing signal			7		
P05.07	Definition of X7 input terminal function	22: Braking contactor testing signal 23: Braking switch testing signal			8		
P05.08	Number of digital input filtering	34: Inching input signal 35: Hardware base block signal(coordinating the	1~99	time s	5		
P05.09	Frequency of inching operation	controlling of KMY and KMB sequential logic) Other: Reserved	0~655.3 5	Hz	0		
P05.10	Acceleration time 2 (inching acceleration time)		0.1~ 360.00	S	5.00		
P05.11	Deceleration time 2 (inching deceleration time)		0.1~ 360.00	S	5.00		
P06	Parameter for digital output						
P06.00	Output function definition K1 Port (Relay)	Set digital output terminal function: 0: No definition; 1: Inverter operation	0~15 101~ 115	×	0		Relay matching K1 has three output terminals, 1A, 1B and 1C. Contact between 1A and 1B is NO. 1B and 1C is NC

Function code	Name	Content	Setting range	Unit	Factory default	Remarks
P06.01	Output function definition K2 Port (Relay)	preparation completion; 2: Inverter fault; 3: Inverter running signal(RUN);			0	Relay matching K2 has three output terminals, 2A, 2B and 2C. Contact between 2A and 2B is NO. 2B and 2C is NC
P06.02	Output function definition Y0 Port	4: Frequency reached signal(FAR); 5: Frequency speed consistent(FDT);			3	Terminal Y0 is inverter operation signal
P06.03	Output function definition Y1 Port	6: Inverter running at 0 speed; 7: DC bus voltage is not less than 85% of the rated voltage; 8: Greater than 5% the rated current during operation, greater than 10% of the rated current at stop;			2	Terminal Y1 is inverter fault signal
P06.04	Output function definition Y2 Port	9: Being self-adjusting			0	
P06.05	Output function definition Y3 Port	10: Speed detection 1; 11: Speed detection 2; 12: When fault forecasted, output 1;when normal, output 0; 13: Self-adjusting request (synchronous motor); 14: Zero servo torque direction output; 15: Zero current detected; 16: Distinguish the state of power generation or motor; 17: Output contactor control; 18: Brake control; 21: Radiator heat output; 23: Deceleration output; 19, 20, 22, 24 and so on are reserved.			0	
P06.06	K1 terminal output delay	Set delay action time of output terminal K1 after actual ON signal	0.0~ 60.0	s	0	
P06.07	K1 terminal reset delay	Set delay reset time of output terminal K1 after actual OFF signal	0.0~ 60.0	s	0	

Function code	Name	Content	Setting range	Unit	Factory default	Remarks
P06.08	K2 terminal output delay	Set delay action time of output terminal K2 after actual ON signal	0.0~ 60.0	s	0	
P06.09	K2 terminal reset delay	Set delay reset time of output terminal K2 after actual OFF signal	0.0~ 60.0	s	0	
P06.10	Y0 terminal output delay	Set delay action time of output terminal Y0 after actual ON signal	0.0~ 60.0	s	0	
P06.11	Y0 terminal reset delay	Set delay reset time of output terminal Y0 after actual OFF signal	0.0~ 60.0	s	0	
P06.12	Y1 terminal output delay	Set delay action time of output terminal Y1 after actual ON signal	0.0~ 60.0	s	0	
P06.13	Y1 terminal reset delay	Set delay reset time of output terminal Y1 after actual OFF signal	0.0~ 60.0	s	0	
P06.14	Y2 terminal output delay	Set delay action time of output terminal Y2 after actual ON signal	0.0~ 60.0	s	0	
P06.15	Y2 terminal reset delay	Set delay reset time of output terminal Y2 after actual OFF signal	0.0~ 60.0	s	0	
P06.16	Y3 terminal output delay	Set delay action time of output terminal Y3 after actual ON signal	0.0~ 60.0	s	0	
P06.17	Y3 terminal reset delay	Set delay reset time of output terminal Y3 after actual OFF signal	0.0~ 60.0	s	0	
P06.18	Non zero current detect threshold at stopping	When stopping, inverter has current and it is greater than this set value, non zero current detection signal is valid. It is a percentage data. The actual value is this data multiply by the rated current and divided by 100	0.0~ 100.0	%	2.0	
P06.19	Any frequency speed detection	A frequency detection reference data, used with P06.20	0.00~ 60.00	Hz	1.00	Details see following note 7

Function code	Name	Content	Setting range	Unit	Factory default	Remarks
P06.20	Any frequency detection width	A frequency detection width and used with P06.19	0.00~20.00	Hz	0.20	Details see following note 7
P07	Parameter for analog input					
P07.00	AI0 analog input type	Set types of analog input AI0 ~ AI1:	0/1	×	1	
P07.06	AI1 analog input type	0: 0~10V 1: -10V~10V			1	
P07.01	AI0 analog input function	Set functions of analog input AI0 ~ AI1: 0: Invalid (unused port)	0/2/3/4	×	2	The factory default setting for AI0 is analog speed reference
P07.07	AI1 analog input function	2: Analog speed reference 3: Analog torque reference 4: Analog torque compensation reference			0	The factory default setting for AI1 is analog torque compensation
P07.02	AI0 analog input offset	Set offset voltage for AI0 analog input	0.000~20.000	V	10.000	
P07.03	AI0 analog input gain	Set gain value for AI0 analog input, it is a percentage data	0.0~100.0	%	100.0	
P07.04	AI0 analog input filtering time	Set filtering time for AI0 analog input signal	0~30	ms	10	
P07.05	AI0 analog input voltage limit	Set voltage limit for AI0 analog input	0.000~10.000	V	10.000	
P07.08	AI1 analog input offset	Set offset voltage for AI1 analog input	0.000~20.000	V	10.000	
P07.09	AI1 analog input gain	Set gain value for AI1 analog input, it is a percentage data	0.0~100.0	%	100.0	
P07.10	AI1 analog input filtering time	Set filtering time for AI1 analog input signal	0~30	ms	10	
P07.11	AI1 analog input voltage limit	Set voltage limit for AI1 analog input	0.000~10.000	V	10.000	

Function code	Name	Content	Setting range	Unit	Factory default	Remarks
P08	Parameter for analog output					
P08.00	Analog output MO function	Set function of analog output M0 ~ M1 0: no defined			1	
P08.01	Analog output M1 function	1: U phase current 2: V phase current 3: W phase current 6: Speed reference 7: Feedback speed 13: Speed regulator output 14: Current regulator IQ reference 15: Current regulator ID reference 30: Current regulator IQ output 32: DC bus voltage 44: Speed deviation	0~44	×	2	
P08.02	M0 analog output offset	Set voltage offset value of M0 analog output	0.000 ~ 20.000	V	15.000	
P08.03	M0 analog output gain	Set the gain value of M0 analog output	0.0 ~ 1000.0	%	100.0	
P08.04	M1 analog output offset	Set voltage offset value of M1 analog output	0.000 ~ 20.000	V	15.000	
P08.05	M1 analog output gain	Set the gain value of M1 analog output	0.0 ~ 1000.0	%	100.0	
P08.06	Select the data of U01 displayed in LCD	Operator has LCD and LED screen. LED displays one number, LCD can display 8 numbers from U01 ~ U08.	0 ~ 31	x	24	
P08.07	Select the data of U02 displayed in LCD	The definition of parameters are: 0: No definition 1: Needback rpm (rpm)			1	

Function code	Name	Content	Setting range	Unit	Factory default	Remarks
P08.08	Select the data of U03 displayed in LCD	2: Speed reference (Hz) 3: Feedback speed (Hz) 4: Output current (A) 5: Output voltage (V)			25	
P08.09	Select the data of U04 displayed in LCD	6: Output torque (%) 7: Bus voltage (V) 8: Analog input 1 signal (V) 9: Analog input 2 signal (V)			4	
P08.10	Select the data of U05 displayed in LCD	13: Magnetic pole angle at static self-learning 16: Zero servo torque (%) 17: Numbers of interference on encoder Z phase			6	
P08.11	Select the data of U06 displayed in LCD	18: Times of interference on encoder A, B phase 23: Weighing compensation torque (%)			16	
P08.12	Select the data of U07 displayed in LCD	24: Rpm reference (rpm) 25: Speed deviation (rpm) 26: Weighing compensation percentage (%)			7	
P08.13	Select the data of U08 displayed in LCD	27: The encoder C phase center 28: The encoder D center			5	
P08.14	Select data displayed in LED	29: Radiator temperature (°C)			1	
P08.15	Set the ID of the inverter	0~32 are corresponding to the different inverter ID	0~32/90		90	It's a special parameter. If it's inconsistent between the power displayed on the manipulator and the inverter nameplate, please consult factory.
P09	Parameters for Other information					
P09.00	Accumulated power ON time			h		Read only
P09.01	Accumulated operation time			H		Read only

Function code	Name	Content	Setting range	Unit	Factory default	Remarks
P09.02	Max. Temperature of radiator			°C		Read only
P09.03	Hardware version			×		Read only
P09.04	Control panel software version			×		Read only
P09.05	Inverter rated power			KW		Read only
P09.06	Torque direction				1	
P09.07	Electric current loop Kp				1.40	
P09.08	Electric current loop Ki				1.00	
P09.09	Electric current loop Kd				0.00	
P09.10	Bandwidth of Electric current loop			Hz	400.00	
P09.11	Bandwidth of magnetic linkage loop			Hz	0.8	
P09.12	Electric current loop selection				0	
P09.13	Reserved					
P09.14	Filtering time by electric current loop reference (reserved in latest program version)			ms		Not required to modify normally
P09.15	PWM modulation		0~2		1	0: 5 section; 1: 7 section;

Function code	Name	Content	Setting range	Unit	Factory default	Remarks
	mode					2: <40%rpm 7 section, >40% 5section
P09.16	Zero servo compensation		0~100	%	0	
P09.17	Delay of contactor connecting			S	0.8	
P09.18	Braking release delay			S	0.4	
P09.19	Contactor disconnecting delay			S	1.0	
P09.20	Braking delay			S	0.1	
P09.21	Output disconnecting delay			S	0.3	
P09.22	Zero speed threshold			Hz	0.20	
P09.23	Special function selection				0	
P09.24	Three phase current balance coefficient				1.043	
P09.25	Minor fault handling				1	0: relay doesn't output fault 1: relay outputs fault
P09.26	Automatic fault reset time			S	10.0	
P09.27	Automatic fault reset count				3	
P09.28	radiator over heat time			S	0.50	
P09.29	Coefficient of over-speed protection			%	120.00	
P09.30	Time of over-speed protection			S	1.00	

Function code	Name	Content	Setting range	Unit	Factory default	Remarks
P09.31	Voltage threshold for input missing phase			V	55	
P09.32	Braking resistor short times			Times	10	
P09.33	Proof of encoder disconnection			Times	2	
P09.34	Proof of output missing phase			S	2.000	
P09.35	Relay fault voltage			V	65	
P09.36	Encoder fractional frequency coefficient (supporting PG card required)		0~7		0	0: (No frequency division); 1: (2 frequency division); 2: (4 frequency division); 3: (8 frequency division); 4: (16 frequency division); 5: (32 frequency division); 6: (64 frequency division); 7: (128 frequency division) (Note: need the PG card to support)
P09.39	Angle self-learning for synchronous motor when power on		0/1		0	Select whether proceed self-learning of angle when the synchronous motor power on: 0: Not learn; 1: Learn
P09.40	Current gain at self-learning		0~400	%	150	Current gain for angle self-learning of the synchronous motor
P09.41	Threshold for encoder CD phase fault		0~65535		300	If the difference value between encoder absolute position and calculated position is over this set value, fault No. 28 will be reported
P09.43	Threshold for ABZ encoder disconnect		0~100	%	20	Protecting when the speed feedback deviation of synchronous motor is over this

Function code	Name	Content	Setting range	Unit	Factory default	Remarks
	protection					value
P09.44	IGBT protection times		1~6553 5	Times	2	
P09.45	I2t protection selection		0~6553 5		0	
P09.46	ID_0					Inverter internal parameter, not modifiable
P09.47	ID_1					Inverter internal parameter, not modifiable
P09.48	ID_2					Inverter internal parameter, not modifiable
P09.49	ID_3					Inverter internal parameter, not modifiable
P09.50	ID_4					Inverter internal parameter, not modifiable
P09.51	ID_5					Inverter internal parameter, not modifiable
P09.52	ID_6					Inverter internal parameter, not modifiable

B.2 Fault list

Fault code	Fault display	Possible reason	Solution
1	Module over-current protection	Too high voltage at DC terminal	Check network power for fast stop under high inertia load, no dynamic braking
		Possible short connection to peripheral circuit	Check any short circuit between motor and output connection, grounding
		Losing output phase	Check any loose connection for motor and output
		Encoder fault	Check encoder or its wiring
		Hardware poor contact or damage	Need maintenance by professional technician
		Internal component loose	Need maintenance by professional technician
		The power circuit components overheat due to	Check the cooling fan. Check whether the cooling fan power is blocked by dirt or foreign object.

Fault code	Fault display	Possible reason	Solution
		the cooling fan or cooling system problem.	
		Warning: The inverter must started only after eliminating the malfunction causes, avoiding the damage to IGBTs	
2	ADC fault	Current sensor damaged	Replace current sensor
		Problem of current sampling loop	Replace control board
3	Heatsink overheat	Ambient temperature too high	Reduce ambient temperature, increase ventilation. Keep the surrounding temperature below 40 °C or according to this character to test the capacity of the inverter.
		The cooling fan damaged or foreign object entered into the cooling system.	Check whether the fan power cable is well connected, or replace the same model fan or remove the foreign objects.
		Cooling fan is abnormal	Check the cooling fan. Check whether the cooling fan power is correct and whether there is any foreign object blocking the fan.
		Temperature detect circuit fault	Need maintenance by professional technician
4	Braking unit failure	Braking unit damaged	Replace related driving module or control circuit board
		External braking resistor circuit short	Replace the resistance or the wiring connection
5	Blown fuse failure	Fuse blown by high current	Check the fuse circuit connection, or looseness of connectors
6	Over torque output	Too low input voltage	Check input power supply
		Motor stop rotating or abrupt loading change	Prevent motor stopping, reduce abrupt loading change
		Encoder failure	Check encoder or its wiring
		Missing output phase	Check the loose connection of motor and output wiring
7	Speed deviation	Too short acceleration time	Extend acceleration time
		Too high load	Reduce load
		Too low current limit	Increase current limit under allowed range
8	Bus over voltage protection (in acceleration running)	Abnormal input voltage	Check input power supply
		Re-rapid starting during motor in high speed rotating	Wait till motor stop rotating, and re-start

Fault code	Fault display	Possible reason	Solution
	Bus over voltage protection (in deceleration running)	Too high load rotational inertia	Select proper energy consumed braking component
		Too short deceleration time	Extend deceleration time
		Too high braking resistance or no resistor	Connect proper braking resistor
	Bus over voltage protection (running at constant speed)	Abnormal input power	Check input power supply
		Too large load rotational inertia	Select proper energy consumed braking component
		Too high braking resistance or no resistor	Connect proper braking resistor
9	Bus undervoltage	Power voltage lower than minimum equipment working voltage	Check input power supply
		Instantaneous power off	Check input power supply, reset and restart after input power back to normal
		Too high fluctuation of input power voltage	
		Loose power connection block	Check input wiring
		Internal switch power abnormal	Need maintenance by professional technician
		A large starting current load existing in the same power supply system	Alter power system to conform the specification
10	Loss of output phase	Abnormal wiring at inverter output, missing or breaking connection	Check wiring at inverter output side based on operation procedure, eliminate missing, breaking connection
		Loose output terminal block	
		Insufficient motor power, less than 1/20 of maximum applicable inverter motor capacity	Adjust the capacity of inverter or motor
		Unbalanced three phase output	Check the motor wiring Check the consistency of characteristic of inverter output side and DC side terminals
11	Motor over current at low speed (during	Low network voltage	Check input power supply
		Improper motor parameter setting	Set proper motor parameters

Fault code	Fault display	Possible reason	Solution
	acceleration)	Rapid start during motor running	Restart after motor stop running
		The acceleration time for load inertia (GD2) is too short.	Extend the acceleration time
	Motor over current at low speed (during deceleration)	Low network voltage	Check input power supply
		Too large load rotational inertia	Select proper energy consumed braking component
		Improper motor parameter setting	Set proper motor parameters
		Too short deceleration time	Extend deceleration time
		The deceleration time for load inertia (GD2) is too short	Prolong the slowdown time
	Motor over current at low speed (during constant speed)	Abrupt load change in running	Reduce frequency and amplitude of abrupt load change
		Improper motor parameter setting	Set proper motor parameters
12	Encoder failure	Incorrect encoder connection	Correct wiring encoder
		Encoder no signal output	Check encoder and power supply
		Encoder wire disconnected	Re-connect
		Abnormal function code setting	Ensure the proper encoder function code setting
13	Current detected at stopping	Current keep on flowing while motor stops	Slip happens by synchronous motor Need maintenance by professional technician
14	Reversed speed during operation	Reversed speed during operation	Check the abrupt change of external load
		Phase differed between encoder and motor	Change motor or phase order
		Motor reversed by starting, current reaches the limit	Current limitation is too low or motor unmatched
15	Speed detected at stopping	Elevator slip due to loose brake	Check brake
		Encoder interfered or loose	Tighten encoder, eliminate interference
16	Wrong motor phase	Motor reversed connected	Correct connection or adjust parameter

Fault code	Fault display	Possible reason	Solution
17	Over speed in the same direction (in maximum allowed speed)	Synchronous motor over speed by loss of excitation	Check motor
		Wrong angle self-learning for synchronous motor	Re-do the self-learning
		Wrong encoder parameter or interference	Check encoder circuit
		Too large positive load or abrupt load change	Check the reason for abrupt load change
18	Over speed in opposite direction (in maximum allowed speed)	Synchronous motor over speed by loss of excitation	Check motor
		Wrong angle self-learning for synchronous motor	Re-do the self-learning
		Wrong encoder parameter or interference	Check encoder circuit
		Too large reversed load or abrupt load change	Check the reason for abrupt load change
19	UVW encoder wrong phase order	Incorrect encoder connection or wrong parameter	Check connection or change parameter
20	Encoder communication fault	Encoder fault	Check encoder wiring and re-do encoder self-learning
21	abc over current (3 phase instantaneous value)	Motor single phase shorted to earth	Check motor and output circuit
		Encoder fault	Check encoder and correct wiring
		Test loop of drive board fault	Replace drive board
22	Brake detection fault	Inactive output relay	Check relay control loop
		Relay triggered, brake not released	Check the brake power string for loosening or breaks
		No signal detected by feedback component	Tune feedback component
23	Input over-voltage	Too high input voltage	Check whether input voltage matches inverter rating
		Problem by detection loop of switch voltage	Need maintenance by professional technician
24	UVW encoder wire broken	Encoder wiring fault	Wiring block loose or wire broken in connection
25	Reserved for future use		

Fault code	Fault display	Possible reason	Solution
26	Encoder no self-learning	Encoder angle not learned by synchronous motor	Do an encoder self-learning
27	Output over current (valid value)	Too long time operation under overload status. The larger the load, the shorter the time is.	Stop for a while, if problem occurs again after re-operation, check to ensure the load in allowed range.
		Motor blocked	Check motor or brake
		Motor coil short	Check motor
		Output short	Check wiring or motor
28	SIN/COS encoder fault	Damaged encoder or wrong wiring	Check encoder and its wiring
29	Loss input phase	Abnormal voltage at input side	Check grid voltage
		Loss input voltage phase	
		Input terminal block loose	Check input terminal wiring
30	Over speed protection (exceed maximum protected speed limit)	Wrong encoder parameter set or interference	Check encoder circuit
		Abrupt load change	Check the external reason for abrupt load change
		Wrong parameter for over speed protection	Check parameter
31	Over current at motor high speed	Power grid voltage too low	Check input power supply
		Abrupt load in operation	Reduce frequency and amplitude of abrupt load change
		Incorrect motor parameter	Set motor parameter correctly
		Wrong encoder parameter or interference	Check encoder circuit
32	Grounding protection	Wrong wiring	Refer to user manual, correct the wrong wiring
		Abnormal motor	Replace motor, to have a grounding isolation test first
		Large drain current to earth at inverter output side	Need maintenance by professional technician
33	Capacitor aged	Inverter capacitor aged	Need maintenance by professional technician

Fault code	Fault display	Possible reason	Solution
34	External fault	External fault signal input	Check the reason for external fault
35	Unbalance output	Abnormal wiring at inverter output side, missing or broking connection	Check inverter output side wiring follow the operation procedure, eliminate possible missing, broking connection
		Motor three phase unbalance	Check motor
36	Wrong parameter setting	Wrong parameter setting	Modify inverter parameter
37	Current sensor fault	Drive board hardware fault	Need maintenance by professional technician
38	Brake resistor short	Connection of external brake resistor short	Check the wiring of brake resistor
39	Too high instantaneous current	Three phase instantaneous current over and alarm while Ia, Ib and Ic not in operation	Need maintenance by professional technician
40	KMY detection fault	KMY detect contactor signal and KMY control signal don't match	Check the contactor of KMY control and KMY detection
41	Brake switch detection fault	Brake switch detect contactor signal and its control signal don't match	Check brake switch
42	IGBT short circuit protection	She cause is the same as Fault 1.	Check short circuit for motor and output wiring, grounding
44	The input power supply is abnormal	1. The input power supply changes a lot 2. Input contactor abnormally connected 3. Temporary electricity	1. Check the power supply 2. Check input contactor
45	I2t instantaneous over current protection	Same as fault 21,27	Same as fault 21,27
46	I2t valid over current protection		

Appendix C Standard Compatibility



(1) European Low Voltage Directive

AS320 series inverter complies with the standard of EN61800-5-1:2007, and its clause of Low Voltage Directive 2006/95/EC.

This inverter complies also the following standard:

EN61800-5-1:2007: Adjustable speed electrical power drive systems –Part 5-1: Safety requirements-Electrical, thermal and energy.

(2) European EMC Regulations

AS320 series inverter meets the following EMC standards once you start to install the product according the recommendation provided by this handbook.

EN12015.1998 Electromagnetic compatibility-Product family standard for lifts, escalators and passenger conveyors-Emission.

EN12016.2004 Electromagnetic compatibility-Product family standard for lifts, escalators and passenger conveyors-Immunity.

EN61800-3:2004: Power Drive Category D3.

(3) ISO9001 Quality Management System

Shanghai Sigriner STEP Electric Co., Ltd executes the quality management according the standard of ISO9001.

Notice to Customers

Dear customers:

RoHS is the abbreviation for *The restriction of the use of certain hazardous substances in electrical and electronic equipment* which was implemented by EU on July 1st, 2006. It stipulates that in the newly developed electrical and electronic equipment, the following six hazardous substances are restricted: lead, mercury, cadmium, hexavalent chrome, PBB and PBDE.

In China, *the Electronic Information Products Pollution Control Management Measures* was issued on February 28th, 2006 jointly by the Ministry of Information Industry, State Development and Reform Commission, Ministry of Commerce, General State Administration for Industry and Commerce, Administration of Customs of the P.R.C, General Administration of Quality Supervision, Inspection and Quarantine and State Bureau of Environmental Protection, became a RoHS direction of Chinese Version and was enforced. On February 1st, 2008, *electronic waste environmental pollution prevention and control management measures* issued by the State Bureau of Environmental Protection of the P.R.C began to be executed, clearly specifying that the users of electronic and electrical products shall provide or entrust the electronic waste to be disassembled and disposed by the qualified company (including small individual businesses) with corresponding business scope listed in directory (or temporary directory).

All electronic components, PCB filters, wire straps, structural parts used in our products are selected and purchased by following *the Electronic Information Products Pollution Control Management Measures* and RoHS directive. The six hazardous substances (lead, mercury, cadmium, hexavalent chrome, PBB and PBDE), are strictly controlled. During manufacturing PCB components are welded on a XinChi lead free welding production line with a lead free welding technology.

Hazardous substances may be contained in the following assemblies:

Type of assembly	Electronic components	PCB Board	Metal sheet	Radiator	Plastic piece	Conductor
Possible hazardous substances	six hazardous substances: lead, mercury, cadmium, hexavalent chrome, PBB and PBDE					

1) Environment analysis: Our electronic products will produce some heat in operation, which may lead the spread of little amount of hazardous substances. It will not cause any serious consequence for ambient environment. Once the life cycle of those electronic products is end and the product is discarded, the heavy metal and chemical hazardous substances contained in the products may seriously contaminate the soil and water resource.

2) Life cycle of electronic products and devices: Any electronic products and devices has its life cycle and will be discarded, replaced and upgraded by a new product, even it is still functional. The life cycle of our company electronic products is generally not more than 20 years.

3) Electronic products discard treatment: If the discarded electronic products aren't treated properly, it may contaminate the environment. Our customers are required to follow up the related national regulation and set up a reclaiming system. It can't be discarded as a regular household refuse or solid industrial wastes. The discarded products shall be stored in an environment-friendly way, or reclaimed by qualified company, and should be strictly complied with the *electronic waste environmental pollution prevention and control management measures* issued by the State Bureau of Environmental Protection of the P.R.C. Any unqualified individual or company is prohibited in disassembling, utilizing, disposing of electronic wastes.

Please don't throw away the electronic waste together with your ordinary domestic waste. Please call local waste disposing agencies or environment protection agencies for the advice of proper electronic waste handling.

Shanghai STEP Electric Corporation